

# *Owner's Manual*

*Diesel Generator*

**MDE570P**

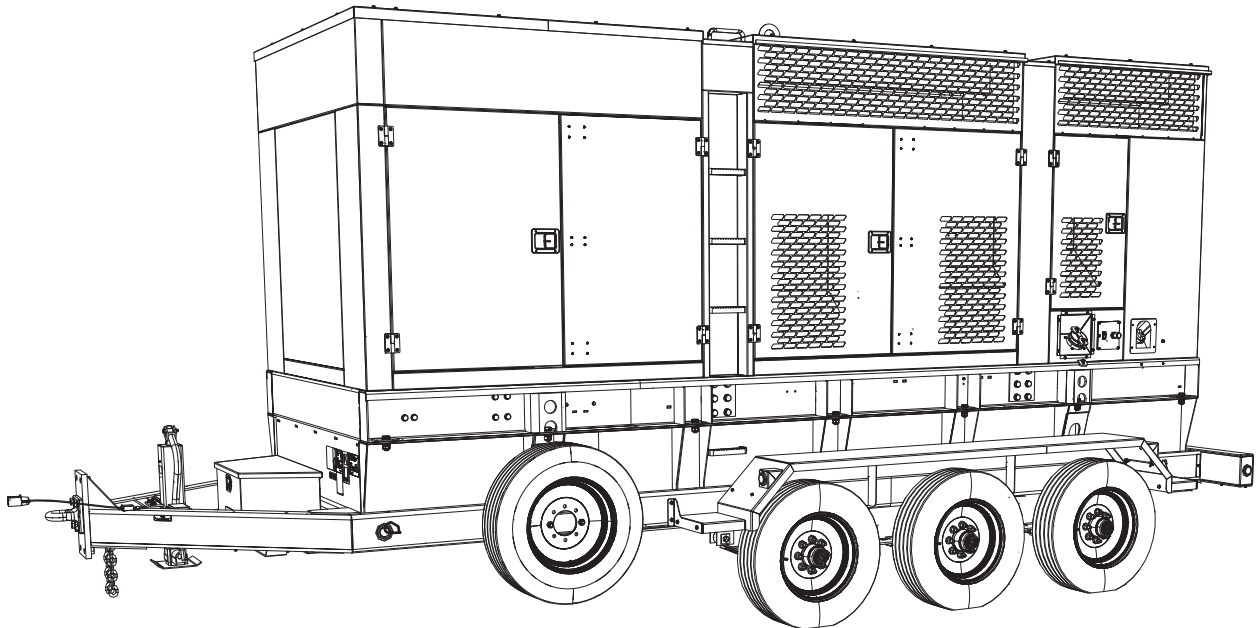

For technical assistance contact:

[www.generacmobileproducts.com](http://www.generacmobileproducts.com)

Technical Support

1-800-926-9768

***SAVE THIS MANUAL FOR FUTURE REFERENCE***

---

**Use this page to record important information about your unit.**

Unit Model No.	
Unit Serial No.	
Engine Model No.	
Engine Serial No.	
Generator Model No.	
Generator Serial No.	

Record the information found on your unit data label on this page. See unit serial number location (***Unit Serial Number Locations***). The label plate is affixed to the inside partition, to the left of the control panel console.

Engine and generator serial numbers are located on separate data plates affixed to the engine and generator.

When contacting a Generac Mobile Authorized Service Dealer (GMASD) about parts and service, supply the complete model number and serial number of the unit.

**Operation and Maintenance:** Proper maintenance and care of the unit ensures a minimum number of problems and keeps operating expenses at a minimum. It is the operator's responsibility to perform all safety checks, to verify that all maintenance for safe operation is performed promptly, and to have the equipment checked periodically by a GMASD. Normal maintenance, service and replacement of parts are the responsibility of the owner or operator and, as such, are not considered defects in materials or workmanship within the terms of the warranty. Individual operating habits and usage may contribute to the need for additional maintenance or service.

 **WARNING**

**CANCER AND REPRODUCTIVE HARM**

[www.P65Warnings.ca.gov](http://www.P65Warnings.ca.gov)

(000393a)

 **WARNING**

Breathing diesel engine exhaust exposes you to chemicals known to the State of California to cause cancer and birth defects or other reproductive harm.

- Always start and operate the engine in a well-ventilated area.
- If in an enclosed area, vent the exhaust to the outside.
- Do not modify or tamper with the exhaust system.
- Do not idle the engine except as necessary.

For more information go to

[www.P65Warnings.ca.gov/diesel](http://www.P65Warnings.ca.gov/diesel)

(000394)

---

# Table of Contents

## **Section 1: Introduction and Safety**

<b>Introduction</b> .....	1
Read This Manual Thoroughly .....	1
How to Obtain Service .....	1
<b>Safety Rules</b> .....	1
<b>Safety Symbols and Meanings</b> .....	1
<b>General Hazards</b> .....	2
<b>Trailer Hazards</b> .....	2
<b>Electrical Hazards</b> .....	3
<b>Lifting Hazards</b> .....	3
<b>Explosion and Fire Hazards</b> .....	3
<b>Battery Hazards</b> .....	4
<b>Fuel Hazards</b> .....	4
<b>Engine Safety</b> .....	4
<b>Operating Safety</b> .....	4
Positioning the Unit .....	4
Starting the Unit .....	5
<b>Towing Safety</b> .....	5
Safe Towing Techniques .....	5
<b>Reporting Trailer Safety Defects</b> .....	5
<b>Safety and Operating Decals</b> .....	5

## **Section 2: General Information**

<b>Specifications</b> .....	9
<b>Unit Dimensions</b> .....	11
<b>Unit ID and VIN Tag Locations</b> .....	12
<b>Altitude and Temperature Limitations</b> .....	12
<b>Wet Stacking</b> .....	12
Load Management System .....	12
<b>Component Locations—Unit Exterior</b> .....	13
<b>Component Locations—Unit Interior</b> .....	14
<b>Component Locations—AC Distribution Panel</b> .....	15
<b>Component Locations—Receptacle Panel</b> .....	16
<b>Component Locations—Control Panel</b> .....	17
<b>Genset Controller</b> .....	18
Genset Controller With Paralleling (If equipped) .....	18
Controller Modes .....	20
Operator Pages .....	20
<b>Maintenance Alarms</b> .....	22
<b>Fuel System</b> .....	23
Fuel Tank .....	23
<b>Engine After treatment Monitoring</b> .....	23
Alternator .....	24

<b>Cold Weather Starting Aids (If Equipped)</b> .....	25
Component Locations .....	25
Recommendations .....	25

## **Section 3: Operation**

<b>Overview</b> .....	27
<b>Prestart Checklist</b> .....	27
<b>Cold Weather Operation</b> .....	27
Using An External Battery Charger .....	28
<b>Using Two-Position Link Board</b> .....	28
Lockout Function .....	29
3-Way Fuel Valve (If equipped) .....	29
Fuel System Priming .....	29
<b>Manually Starting the Unit</b> .....	30
<b>AUTO (Remote) Starting the Unit</b> .....	31
Remote Start Terminal Block .....	31
<b>Parallel Setup and Operation (If equipped)</b> .....	31
Manual Paralleling .....	32
Automatic Paralleling .....	32
Switching Controller Mode .....	32
<b>Fine Tuning the Voltage</b> .....	32
<b>Voltage Regulator</b> .....	33
<b>Main Circuit Breaker</b> .....	33
Motorized Breaker (If equipped) .....	33
<b>Connection Lugs</b> .....	33
Connecting to Lugs .....	34
<b>Cam Lock Connections (If equipped)</b> .....	34
<b>Convenience Receptacles</b> .....	35
Correct Receptacle Use .....	36
<b>Transfer Switch</b> .....	36
<b>Changing Exercise Timers</b> .....	36
<b>PAS, Installation, Operation &amp; Testing (if equipped)</b> .....	37
<b>Shutting Down the Unit</b> .....	37
<b>Emergency Stop Switch</b> .....	38
<b>Towing the Unit</b> .....	38
Hitch and Coupling Guidelines .....	38
Preparing Unit for Towing .....	38
Recommended Towing Speed .....	39
<b>Lifting the Unit</b> .....	39
Trailer and Skid-Mounted Units .....	39
Skid-Mounted Units ONLY .....	39
<b>Dragging the Unit (Skid Mounted Units Only)</b> .....	40

---

Tying Down the Unit .....	40
---------------------------	----

## ***Section 4: Maintenance***

<b>Emissions Information .....</b>	<b>41</b>
<b>Maintenance .....</b>	<b>41</b>
<b>Daily Walk Around Inspection .....</b>	<b>41</b>
<b>General Maintenance .....</b>	<b>41</b>
<b>Fuel Recommendations .....</b>	<b>42</b>
<b>Adding Fuel .....</b>	<b>42</b>
<b>Engine Oil Recommendations .....</b>	<b>42</b>
Commercial Oils .....	42
Aftermarket Oil Additives .....	43
Oil analysis .....	44
<b>Coolant Recommendation .....</b>	<b>44</b>
Acceptable Coolant Types .....	44
Coolant Mixtures and Freezing Points .....	44
<b>DEF Recommendations .....</b>	<b>45</b>
Specification .....	45
Spillage .....	45
Filling the DEF Tank .....	45
<b>Basic Maintenance Schedule .....</b>	<b>46</b>
<b>Resetting Maintenance Alarms .....</b>	<b>49</b>
<b>DEF System Maintenance .....</b>	<b>49</b>
DEF Testing .....	49
DEF Tank Cleaning .....	49
DEF Disposal .....	49
DEF Storage Guidelines .....	50
<b>DOC, SCR, and DPF Cleaning Operations .....</b>	<b>50</b>
<b>Diesel Particulate Filter Regeneration .....</b>	<b>50</b>
Regeneration Indicators .....	51
Modes of Regeneration .....	51
Regeneration Triggers .....	51
Regeneration System Warning Indicators .....	51
<b>Checking Generator Drive Plate Torque .....</b>	<b>52</b>
<b>Jack Maintenance .....</b>	<b>52</b>
Side-Wind Models .....	52
Top-Wind Models .....	53
<b>Trailer Wheel Bearings .....</b>	<b>53</b>

## ***Section 5: Troubleshooting***

<b>General Troubleshooting .....</b>	<b>55</b>
--------------------------------------	-----------

## ***Section 6: Wiring Diagrams***

<b>Wiring Diagrams .....</b>	<b>57</b>
------------------------------	-----------



# Section 1: Introduction and Safety

---

## Introduction

Thank you for purchasing a Generac Mobile product. This unit has been designed to provide high performance, efficient operation, and years of use when maintained properly.

The information in this manual is accurate based on products produced at the time of publication. The manufacturer reserves the right to make technical updates, corrections, and product revisions at any time without notice.

## Read This Manual Thoroughly



Consult Manual. Read and understand manual completely before using product. Failure to completely understand manual and product could result in death or serious injury. (000100a)

If any section of this manual is not understood, contact your nearest GMASD, or contact Generac Mobile Technical Service at 1-800-926-9768 or [www.generacmobileproducts.com](http://www.generacmobileproducts.com) with any questions or concerns.

The owner is responsible for proper maintenance and safe use of the equipment. Comply with regulations the Occupational Safety and Health Administration (OSHA) has established, or with equivalent standards. Also, verify that the unit is applied, used, and maintained in accordance with the manufacturer's instructions and recommendations. Do nothing that might alter safe application/usage and render the unit in noncompliance with the aforementioned codes, standards, laws, and regulations.

Save these instructions for future reference. This manual contains important instructions for the unit that should be followed during setup, operation and maintenance of the unit and battery. ALWAYS supply this manual to any individual that will use this machine.

## How to Obtain Service

When the unit requires servicing or repairs, contact a GMASD for assistance. Service technicians are factory-trained and are capable of handling all service needs. For assistance locating a dealer, go to <https://www.generacmobileproducts.com/parts-service/find-service>.

When contacting a GMASD about parts and service, always supply the complete model and serial number of the unit as given on the data decal located on the unit. Record the model and serial numbers in the spaces provided on the front cover of this manual.

## Safety Rules

The manufacturer cannot anticipate every possible circumstance that might involve a hazard. The warnings in this manual, and on tags and decals affixed to the unit are, therefore, not all inclusive. If using a procedure, work method or operating technique that the manufacturer does not specifically recommend, verify it is safe for others. Also make sure the procedure, work method, or operating technique utilized does not render the equipment unsafe.

## Safety Symbols and Meanings

Throughout this publication, and on tags and decals affixed to the unit, DANGER, WARNING, CAUTION and NOTE blocks are used to alert personnel to special instructions about a particular operation that may be hazardous if performed incorrectly or carelessly. Observe them carefully. Their definitions are as follows:



Indicates a hazardous situation which, if not avoided, will result in death or serious injury.

(000001)



Indicates a hazardous situation which, if not avoided, could result in death or serious injury.

(000002)



Indicates a hazardous situation which, if not avoided, could result in minor or moderate injury.

(000003)

**NOTE:** Notes contain additional information important to a procedure and will be found within the regular text of this manual.

These safety alerts cannot eliminate the hazards that they indicate. Common sense and strict compliance with the special instructions while performing the action or service are essential to preventing accidents.

---

## General Hazards

**⚠ DANGER**

Asphyxiation. Running engines produce carbon monoxide, a colorless, odorless, poisonous gas. Carbon monoxide, if not avoided, will result in death or serious injury. (000103)

---

**⚠ DANGER**

Asphyxiation. Do not operate unit without a properly functioning exhaust system. Doing so will result in death or serious injury. (000340)

---

**⚠ WARNING**

Loss of life. This product is not intended to be used in a critical life support application. Failure to adhere to this warning could result in death or serious injury. (000209b)

---

**⚠ WARNING**

Hearing Loss. Hearing protection is recommended when using this machine. Failure to wear hearing protection could result in permanent hearing loss. (000107)

---

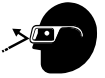
**⚠ WARNING**

Vision Loss. Eye protection is required to avoid spray from spark plug hole when cranking engine. Failure to do so could result in vision loss. (000181)

---

**⚠ WARNING**

Moving Parts. Keep clothing, hair, and appendages away from moving parts. Failure to do so could result in death or serious injury. (000111)

---

**⚠ WARNING**

Hot Surfaces. When operating machine, do not touch hot surfaces. Keep machine away from combustibles during use. Hot surfaces could result in severe burns or fire. (000108)

---

**⚠ WARNING**

Equipment damage. Do not attempt to start or operate a unit in need of repair or scheduled maintenance. Doing so could result in serious injury, death, or equipment failure or damage. (000291)

---

**⚠ WARNING**

Risk of injury. Do not operate or service this machine if not fully alert. Fatigue can impair the ability to operate or service this equipment and could result in death or serious injury. (000215a)

---

**⚠ WARNING**

Equipment damage. Only qualified service personnel may install, operate, and maintain this equipment. Failure to follow proper installation requirements could result in death, serious injury, and equipment or property damage. (000182a)

---

**⚠ CAUTION**

Equipment or property damage. Do not block air intake or restrict proper air flow. Doing so could result in unsafe operation or damage to unit. (000229)

---

## Trailer Hazards

**⚠ WARNING**

Personal injury. Trailer must be securely coupled to the hitch with the chains correctly attached. Uncoupled or unchained towing could result in death or serious injury. (000233a)

---

**⚠ WARNING**

Personal injury. Do not operate unit during transport. Doing so could result in death, serious injury, or property damage. (000231a)

---

**⚠ WARNING**

Crushing hazard. Verify unit is properly secured and on level ground. An unsecured unit can suddenly roll or move, causing death or serious injury. (000234a)

---

**⚠ WARNING**

Property or Equipment Damage. Tighten wheel lug nuts after first 50 miles to factory specifications. Failure to do so could result in death, serious injury, property or equipment damage. (000235)

---

---

## Electrical Hazards

---



**⚠ DANGER**

Electrocution. In the event of electrical accident, immediately shut power OFF. Use non-conductive implements to free victim from live conductor. Apply first aid and get medical help. Failure to do so will result in death or serious injury. (000145)

---



**⚠ DANGER**

Electrocution. Water contact with a power source, if not avoided, will result in death or serious injury. (000104)

---



**⚠ DANGER**

Electrocution. Contact with bare wires, terminals, and connections while generator is running will result in death or serious injury. (000144)

---



**⚠ DANGER**

Electrocution. Verify electrical system is properly grounded before applying power. Failure to do so will result in death or serious injury. (000152)

---



**⚠ DANGER**

Electrocution. Turn utility supply OFF before working on utility connections of the transfer switch. Failure to do so will result in death or serious injury. (000123)

---



**⚠ DANGER**

Electrocution. Never connect this unit to the electrical system of any building unless a licensed electrician has installed an approved transfer switch. Failure to do so will result in death or serious injury. (000150)

---



**⚠ WARNING**

Electrical shock. Disconnect battery ground terminal before working on battery or battery wires. Failure to do so could result in death or serious injury. (000164)

---

---

## Lifting Hazards

---



**⚠ WARNING**

Personal injury. Failure to properly connect lifting cables, chains, or straps could result in death, serious injury, or property damage. (000346)

---

**⚠ WARNING**

Personal Injury. Do not use lifting hook if there are signs of damage or corrosion. Doing so could result in death, serious injury, or property damage. (000349)

---

**⚠ WARNING**

Personal Injury. Do not use lifting hook other than as directed. Failure to do so could result in death, serious injury, or property damage. (000350)

---

**⚠ WARNING**

Personal Injury. Verify all fasteners are properly tightened prior to lifting unit. Failure to do so could result in death, serious injury, or property damage. (000351)

---

---

## Explosion and Fire Hazards

---



**⚠ DANGER**

Explosion and Fire. Fuel and vapors are extremely flammable and explosive. Add fuel in a well ventilated area. Keep fire and spark away. Failure to do so will result in death or serious injury. (000105)

---



**⚠ WARNING**

Fire risk. Fuel and vapors are extremely flammable. Do not operate indoors. Doing so could result in death, serious injury, or property or equipment damage. (000281)

---



**⚠ WARNING**

Risk of Fire. Unit must be positioned in a manner that prevents combustible material accumulation underneath. Failure to do so could result in death or serious injury. (000147)

---

## Battery Hazards



### **⚠ DANGER**

Electrocution. Do not wear jewelry while working on this equipment. Doing so will result in death or serious injury.

(000188)



### **⚠ WARNING**

Explosion. Batteries emit explosive gases while charging. Keep fire and spark away. Wear protective gear when working with batteries. Failure to do so could result in death or serious injury.

(000137a)



### **⚠ WARNING**

Risk of burns. Batteries contain sulfuric acid and can cause severe chemical burns. Wear protective gear when working with batteries. Failure to do so could result in death or serious injury.

(000138a)



### **⚠ WARNING**

Explosion. Do not dispose of batteries in a fire. Batteries are explosive. Electrolyte solution can cause burns and blindness. If electrolyte contacts skin or eyes, flush with water and seek immediate medical attention.

(000162)



### **⚠ WARNING**

Risk of burn. Do not open or mutilate batteries. Batteries contain electrolyte solution which can cause burns and blindness. If electrolyte contacts skin or eyes, flush with water and seek immediate medical attention.

(000163a)

### **⚠ WARNING**

Environmental Hazard. Always recycle batteries at an official recycling center in accordance with all local laws and regulations. Failure to do so could result in environmental damage, death, or serious injury.

(000228)

Always recycle batteries in accordance with local laws and regulations. Contact your local solid waste collection site or recycling facility to obtain information on local recycling processes. For more information on battery recycling, visit the Battery Council International website at: <http://batteryCouncil.org>.

## Fuel Hazards



### **⚠ DANGER**

Explosion and fire. Fuel and vapors are extremely flammable and explosive. No leakage of fuel is permitted. Keep fire and spark away. Failure to do so will result in death or serious injury.

(000192)



### **⚠ DANGER**

Risk of fire. Allow fuel spills to completely dry before starting engine. Failure to do so will result in death or serious injury.

(000174)

- **DO NOT** fill fuel tank near an open flame, while smoking, or while engine is running. **DO NOT** fill tank in an enclosed area with poor ventilation.
- **DO NOT** operate with the fuel tank cap loose or missing.

## Engine Safety

Internal combustion engines present special hazards during operation and fueling. Failure to follow the safety guidelines described below could result in severe injury or death. Read and follow all safety alerts described in the engine operator's manual. A copy of this manual was supplied with the unit when it was shipped from the factory.

- **DO NOT** run engine indoors or in an area with poor ventilation. Verify engine exhaust cannot seep into closed rooms or ventilation equipment.
- **DO NOT** clean air filter with gasoline or other types of low flash point solvents.
- **DO NOT** operate the unit without a functional exhaust system.
- Shut the engine down if any of the following conditions exist during operation:
  - Abnormal change in engine speed.
  - Loss of electrical output.
  - Equipment connected to the unit overheats.
  - Sparking occurs.
  - Engine misfires or there is excessive engine/generator vibration.
- Protective covers are loose or missing.

## Operating Safety

### Positioning the Unit

### **⚠ WARNING**

Crushing hazard. Verify unit is properly secured and on level ground. An unsecured unit can suddenly roll or move, causing death or serious injury.

(000234a)

- The area immediately surrounding the unit should be dry, clean, and free of debris.
- If the unit is equipped with a frame grounding stud, follow any local, state, and National Electrical Code (NEC) guidelines when connecting.

---

## Starting the Unit



**⚠ DANGER**

Electrocution. DO NOT use the unit if electrical cord is cut or worn through. Doing so will result in death or serious injury.

(000263a)

- **DO NOT** start a unit in need of repair.

## Towing Safety

Towing a trailer requires care. Both the trailer and vehicle must be in good condition and securely fastened to each other to reduce the possibility of an accident. Some states require that large trailers be registered and licensed. Contact your local Department of Transportation office to check on license requirements for your particular unit.

### Safe Towing Techniques

- Practice turning, stopping, and backing up in an area away from heavy traffic before transporting the unit.
- Maximum recommended speed for highway towing is 65 mph (105 km/h). Recommended off-road towing speed is 10 mph (16 km/h) or less, depending on terrain.
- When towing, maintain extra space between vehicles and avoid soft shoulders, curbs, and sudden lane changes.

## Reporting Trailer Safety Defects

If you believe your trailer has a defect which could cause a crash or could cause injury or death, you should immediately inform the National Highway Traffic Safety Administration (NHTSA) in addition to notifying Generac Mobile.

If NHTSA receives similar complaints, it may open an investigation. If it finds that a safety defect exists in a group of vehicles, it may order a recall and remedy campaign. However, NHTSA cannot become involved in an individual problem between you, your GMASD, or Generac Mobile.

To contact NHTSA, you may either call the Auto Safety Hotline toll-free at 1-888-327-4236 (TTY: 1-800-424-9153), go to <http://www.safercar.gov>; or write to:

Administrator  
NHTSA  
1200 New Jersey Avenue S.E.  
Washington, DC 20590

You can also obtain other information about motor vehicle safety from <http://www.safercar.gov>.

## Safety and Operating Decals

IMPORTANT NOTE: Replace missing and hard-to-read decals. Use care when washing or cleaning the unit. See the parts manual at [www.generacmobileproducts.com](http://www.generacmobileproducts.com) for decal part numbers.



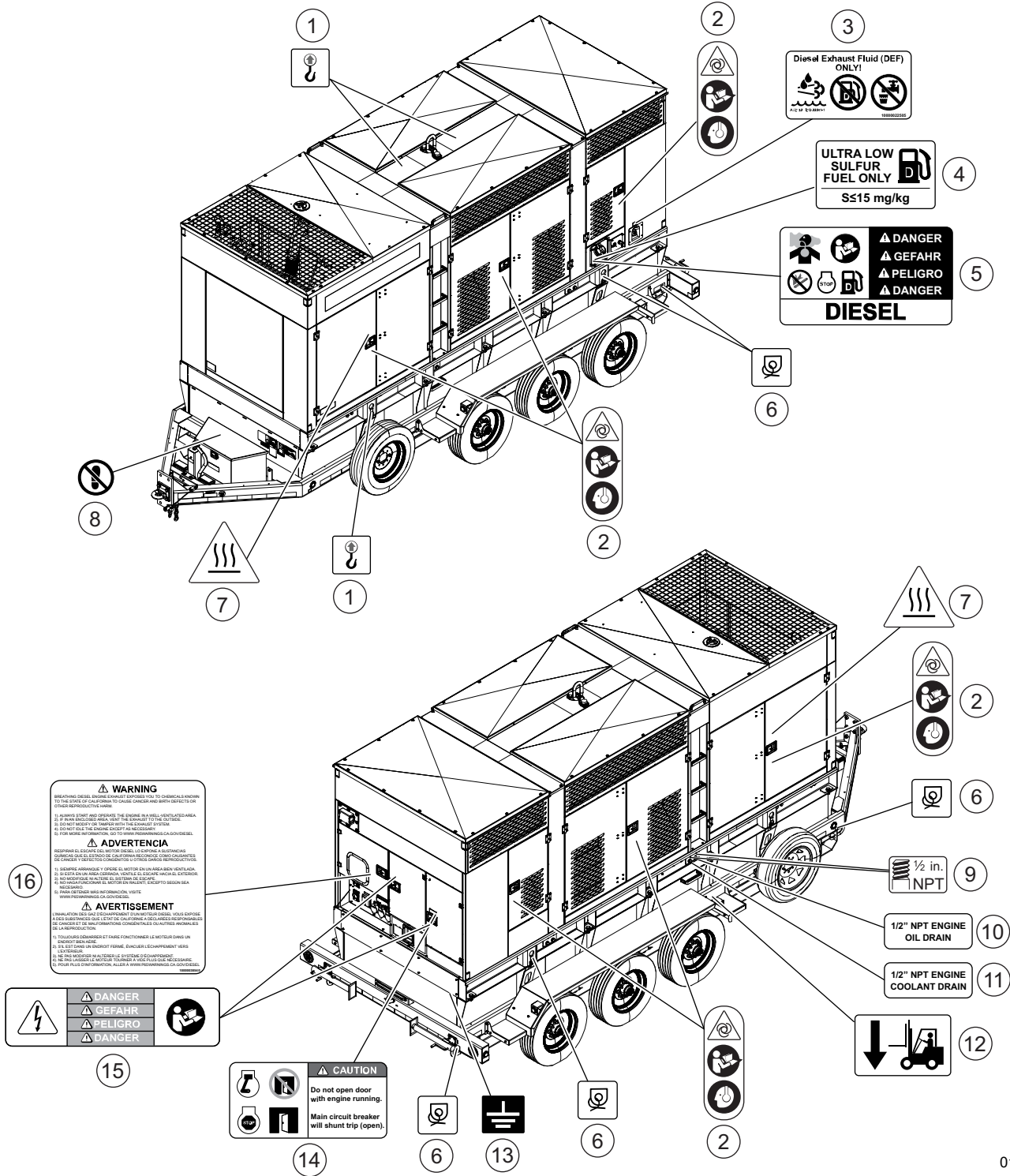
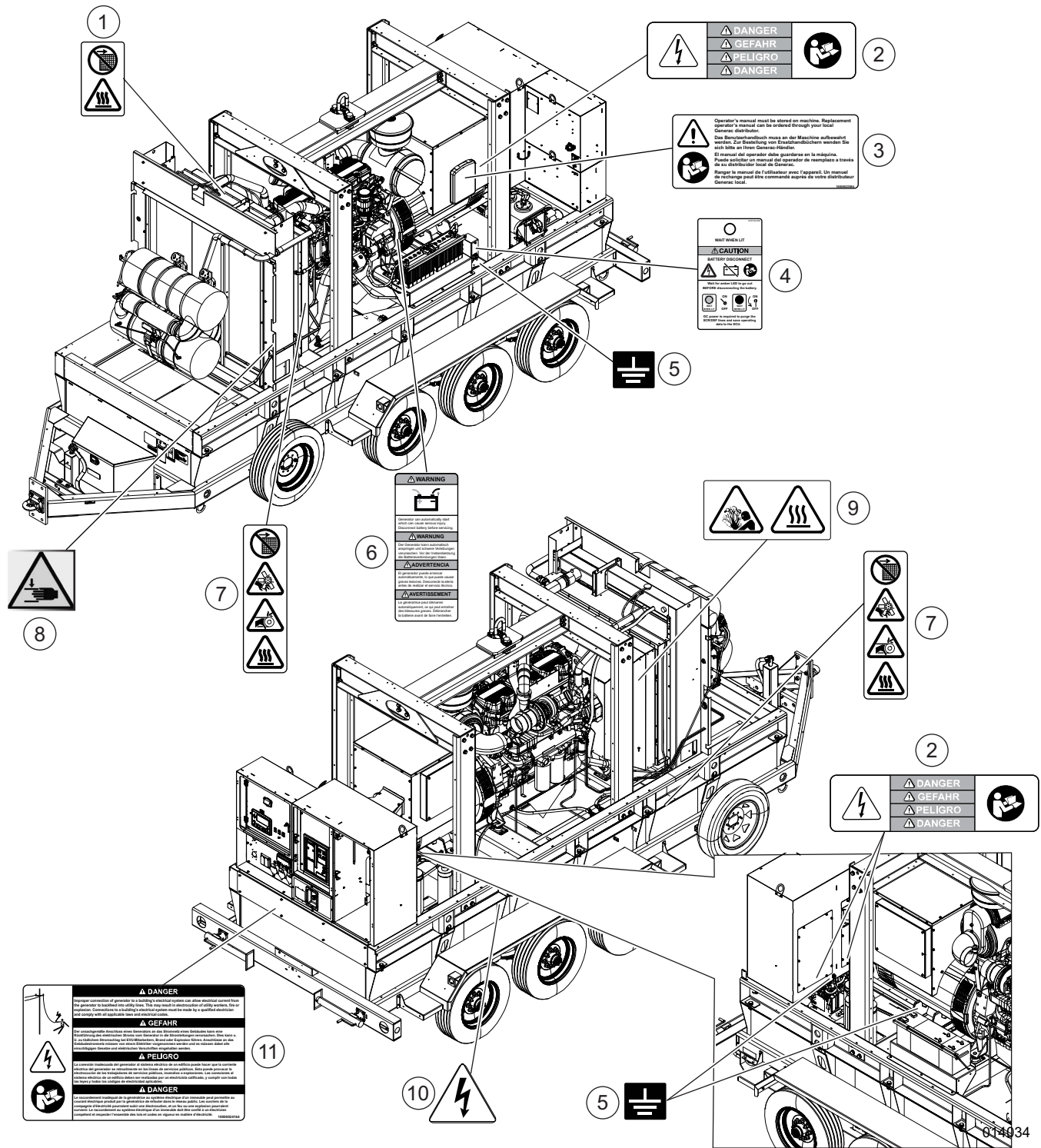

Figure 1-1. Exterior Decals

- |   |  |    |   |
|---|--|----|---|
| 1 | Overhead lift point                      | 9  | ISO thread ½ NPT                                |
| 2 | Noise and auto-start hazards—read manual | 10 | Engine oil drain                                |
| 3 | DEF fluid only                           | 11 | Engine coolant drain                            |
| 4 | Ultra low sulfur fuel only               | 12 | Forklift pocket below                           |
| 5 | Danger: Diesel fuel hazards              | 13 | Connection lug ground                           |
| 6 | Tie-down point                           | 14 | Do not open door with engine running—shunt trip |
| 7 | High temperature hazard                  | 15 | Electrical danger—read manual                   |
| 8 | Do not step                              | 16 | CA Proposition 65 warning                       |



**Figure 1-2. Interior Decals**

- |   |   |
|---|---|
| <p>1 Radiator fill hazard</p> <p>2 Electrical danger—read manual</p> <p>3 Operator Manual Storage</p> <p>4 Battery disconnect</p> <p>5 Connection lug ground</p> <p>6 Warning: Auto-start—Disconnect battery before service</p> | <p>7 Fan belt blade temp guard</p> <p>8 Pinch point hazard</p> <p>9 Gen guard temp warning</p> <p>10 Electrical hazard</p> <p>11 Danger: Only qualified personnel may install equipment</p> |
|---|---|

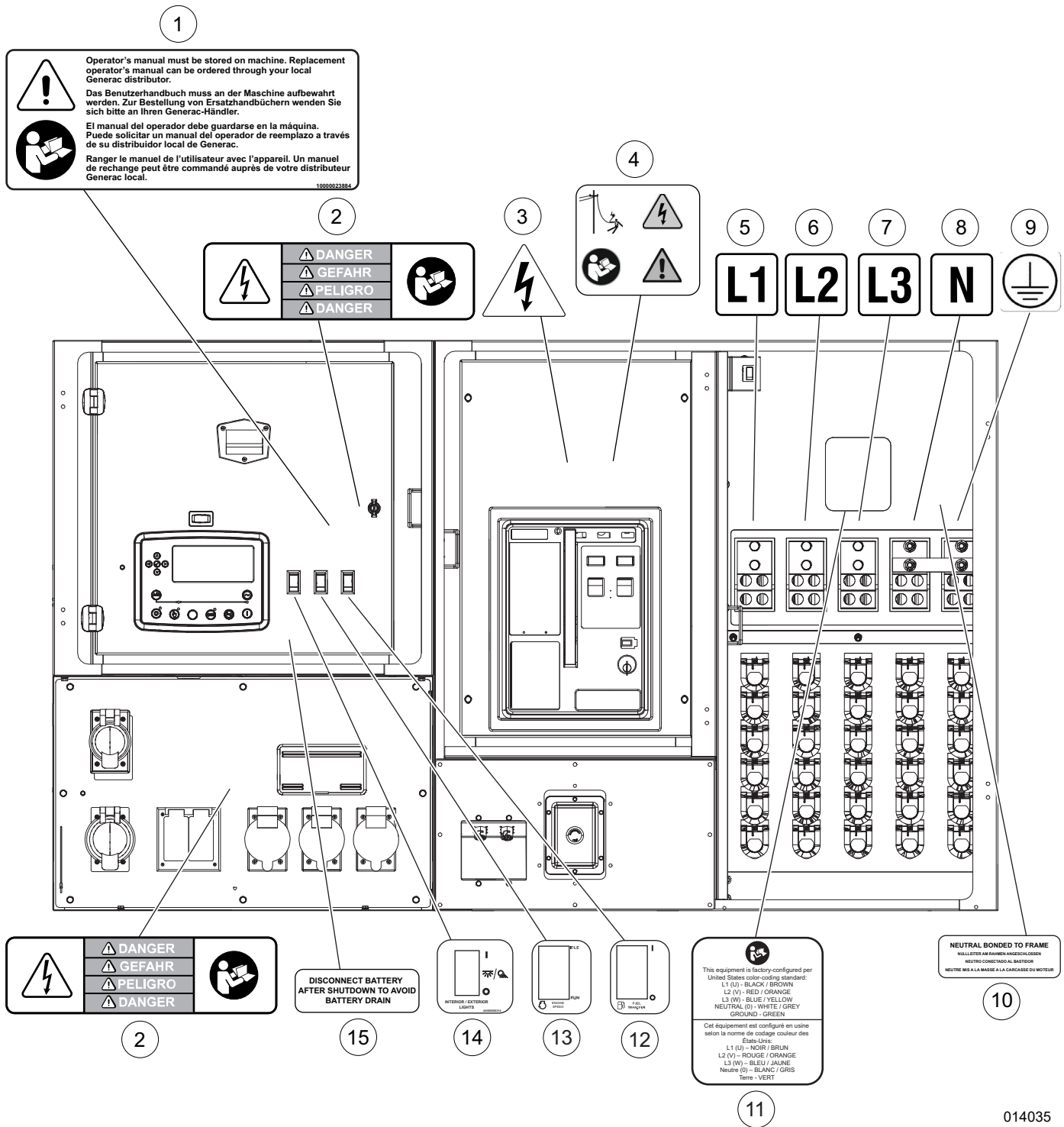

014035

**Figure 1-3. Panel Decals**

- |          |                               |           |                                |
|----------|-------------------------------|-----------|--------------------------------|
| <b>1</b> | Operator manual storage       | <b>9</b>  | Connection lug GND 32 mm       |
| <b>2</b> | Electrical danger—read manual | <b>10</b> | Neutral bonded to frame        |
| <b>3</b> | Electrical hazard             | <b>11</b> | US cam lock—single pin         |
| <b>4</b> | ISO generator backfeed        | <b>12</b> | Fuel transfer switch           |
| <b>5</b> | Connection lug L1 32 mm       | <b>13</b> | Engine speed switch            |
| <b>6</b> | Connection lug L2 32 mm       | <b>14</b> | Interior-exterior light switch |
| <b>7</b> | Connection lug L3 32 mm       | <b>15</b> | Disconnect battery             |
| <b>8</b> | Connection lug NEU 32 mm      |           |                                |



# Section 2: General Information

## Specifications

Description	Unit Of Measure	MDE570P
<b>Engine</b>		
Make (Model)	—	Perkins® (2806F-E18TAG1)
Rated Power Output—Prime	hp (kW)	670 (500)
Operating Speed	rpm	1,800
Fuel Consumption—100% Prime	gph (L/hr)	33.0 (124.9)
Fuel Consumption—75% Prime	gph (L/hr)	24.7 (93.5)
Fuel Consumption—50% Prime	gph (L/hr)	16.8 (63.3)
DEF Consumption—100% Prime	gph (L/hr)	1.2 (4.4)
EPA—Emissions Certification	Tier	4 Final
Battery—Group Number	—	31
Battery—Voltage (Quantity Of Batteries)	VDC (qty)	24 (2)
Battery—Rating	CCA	950
<b>Generator</b>		
<b>Standard Generator</b>		
Make (Model)	—	Leroy Somer™ (LSA 47.2 M7)
Frequency	Hz	60
Excitation Method	—	PMG
Power Output:		
3Ø Standby:		
208/120 VAC	kW/kVA (A)	460/575 (1,598)
240/139 VAC	kW/kVA (A)	500/625 (1,505)
480/277 VAC	kW/kVA (A)	500/625 (753)
3Ø Prime:		
208/120 VAC	kW/kVA (A)	456/570 (1,584)
240/139 VAC	kW/kVA (A)	456/570 (1,372)
480/277 VAC	kW/kVA (A)	456/570 (686)
<b>Optional SUPERSTART® Generator</b>		
Make (Model)	—	Leroy Somer (LSA 47.2 M8)
Frequency	Hz	60
Excitation Method	—	PMG
Power Output:		
3Ø Standby:		
208/120 VAC	kW/kVA (A)	460/575 (1,598)
240/139 VAC	kW/kVA (A)	500/625 (1,505)
480/277 VAC	kW/kVA (A)	500/625 (753)
3Ø Prime:		
208/120 VAC	kW/kVA (A)	456/570 (1,584)
240/139 VAC	kW/kVA (A)	456/570 (1,372)
480/277 VAC	kW/kVA (A)	456/570 (686)
<b>Optional VFLEX Generator</b>		
Make (Model)	—	Leroy Somer (LSA 47.2 L9)
Frequency	Hz	60
Excitation Method	—	PMG
Power Output:		
3Ø Standby:		
208/120 VAC	kW/kVA (A)	460/575 (1,598)
240/139 VAC	kW/kVA (A)	500/625 (1,505)

Description	Unit Of Measure	MDE570P
480/277 VAC	kW/kVA (A)	500/625 (753)
600/346 VAC	kW/kVA (A)	500/625 (602)
3Ø Prime:		
208/120 VAC	kW/kVA (A)	456/570 (1,584)
240/139 VAC	kW/kVA (A)	456/570 (1,372)
480/277 VAC	kW/kVA (A)	456/570 (686)
600/346 VAC	kW/kVA (A)	456/570 (549)
<b>Weights</b>		
<b>Skid Mounted</b>		
Dry	lb (kg)	17,482 (7,928)
Operating (Maximum)	lb (kg)	23,375 (10,600)
<b>Trailer Mounted</b>		
Dry	lb (kg)	19,951 (9,048)
Operating (Maximum)	lb (kg)	25,844 (11,720)
<b>Capacities</b>		
Standard Single Wall Fuel Tank—Total	gal (L)	760 (2,876)
Standard Single Wall Fuel Tank—Usable	gal (L)	671 (2,540)
Optional Double Wall Fuel Tank—Total	gal (L)	696 (2,635)
Optional Double Wall Fuel Tank—Usable	gal (L)	661 (2,502)
DEF Tank—Total	gal (L)	28.3 (107.1)
DEF Tank—Usable	gal (L)	24.7 (93.5)
Coolant—Including Engine	gal (L)	16.7 (63.2)
Oil—Including Filter	gal (L)	19.5 (74)
<b>Run Time</b>		
Fuel Tank—75% Load	hr	27.1
<b>AC Distribution</b>		
Circuit Breaker Size	A	1,600
<b>Trailer</b>		
Hitch—Standard	Size, Type	3 in (76.2 mm), Ring
Maximum Tire Pressure	psi (kPa)	125 (862)

*Specifications are subject to change without notice.*

# Unit Dimensions

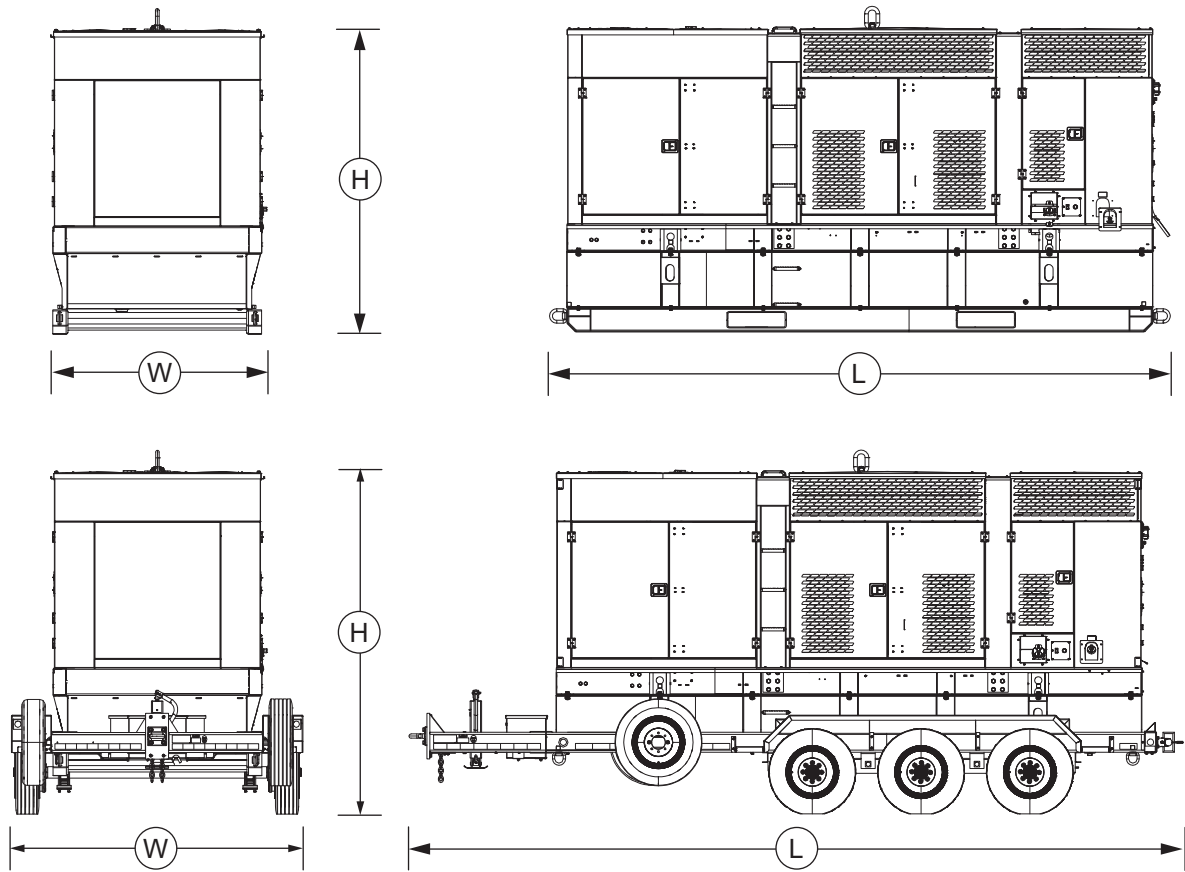

01348

**Figure 2-1. Unit Dimensions**

	<b>L</b>	<b>W</b>	<b>H</b>
Skid Mounted	204.8 in (5.2 m)	73.0 in (1.9 m)	109.0 in (2.8 m)
Trailer Mounted	260.0 in (6.6 m)	102.0 in (2.6 m)	118.8 in (3.0 m)

## Unit ID and VIN Tag Locations

See **Figure 2-2** The unit ID tag is located on the control panel face. The vehicle identification number (VIN) tag (B) is located on the drivers side of the trailer tongue. Important information such as the unit model number, serial number, VIN, and tire loading information are listed on the tags. Record the information from the tags in the event the tags are lost or damaged. This information may be required when ordering parts or requesting assistance.

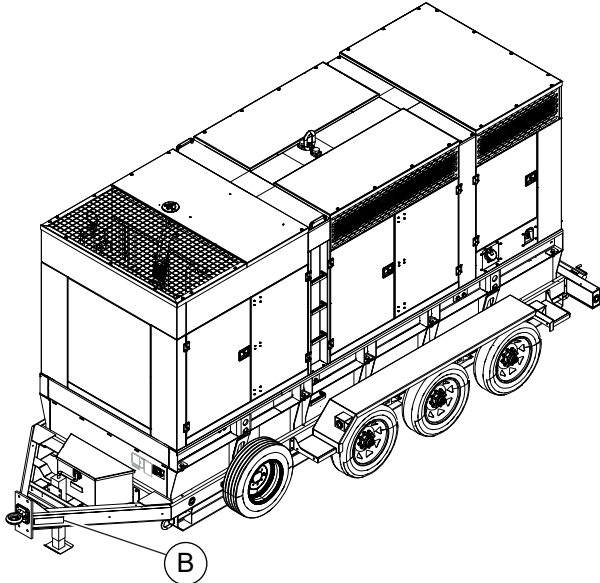

**Figure 2-2. Unit ID and VIN Tag Locations**

## Altitude and Temperature Limitations

All units are subject to derating for altitude and temperature. Derating reduces the power available for operating tools and accessories connected to the outlets.

- **Altitude:** This unit can provide full prime power up to 1,640 ft (500 m) above sea level. Above that, power output to outlets is reduced by 2% for every additional 820 ft (250 m) of elevation.
- **Temperature:** This unit can provide full prime power up to 110 °F (43 °C) ambient air temperature. Above that, operating the unit at full power causes the coolant to overheat, resulting in engine shutdown. Maximum coolant temperature is 225 °F (107 °C).

## Wet Stacking

This unit is powered by a diesel engine. Wet stacking is a condition in diesel engines in which not all fuel is burned. Unburned diesel fuel passes into the exhaust system, where it accumulates. Wet stacking is often caused by operating the engine below about 30% of its rated capacity. Damaging effects fuel injector fouling, oily buildup on engine valves, and deposits on aftertreatment components. Always operate the engine between 30%

and 100% of its rated capacity. Appropriate generator sizing is determined by the anticipated load.

## Load Management System

This engine is equipped with a standard exhaust temperature management (ETM) load management system.

When a low-load condition exists, ETM activates a regeneration cycle, introducing heat into the exhaust system. This process helps to maintain proper operating temperatures in the exhaust, and helps to clean catalyts of deposits due to low loading.

## Component Locations—Unit Exterior

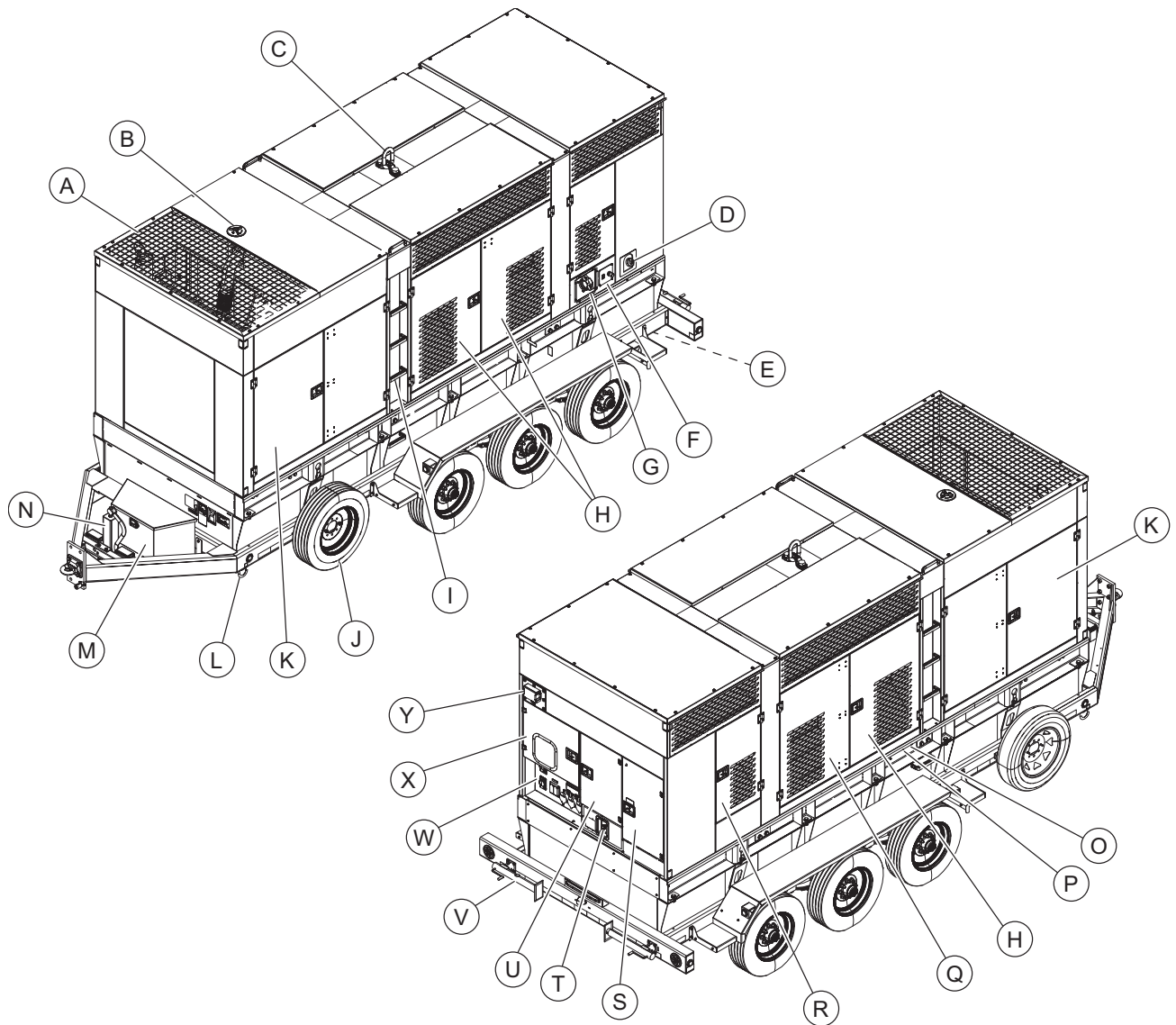

014004

**Figure 2-3. Exterior Components**

- |  |  |
|--|--|
| <b>A</b> Hot air/exhaust duct                      | <b>N</b> Tongue jack                                 |
| <b>B</b> Radiator/coolant fill access panel        | <b>O</b> Coolant drain                               |
| <b>C</b> Central lift point                        | <b>P</b> Engine oil drain                            |
| <b>D</b> Diesel exhaust fluid (DEF) fill port      | <b>Q</b> Link board access door                      |
| <b>E</b> DEF drain (not shown—unit underside)      | <b>R</b> Generator access door                       |
| <b>F</b> Extended run fuel system (if equipped)    | <b>S</b> 3-phase AC power distribution access door   |
| <b>G</b> Fuel fill                                 | <b>T</b> Emergency stop switch                       |
| <b>H</b> Engine and generator (genset) access door | <b>U</b> Breaker panel access door                   |
| <b>I</b> Ladder                                    | <b>V</b> Stabilizer jack (2 locations) (if equipped) |
| <b>J</b> Spare tire (2 locations) (if equipped)    | <b>W</b> Receptacle panel                            |
| <b>K</b> Exhaust system access door                | <b>X</b> Control panel access door                   |
| <b>L</b> Tie-down point (4 locations)              | <b>Y</b> Telemetry (if equipped)                     |
| <b>M</b> Toolbox (if equipped)                     |  |

## Component Locations—Unit Interior

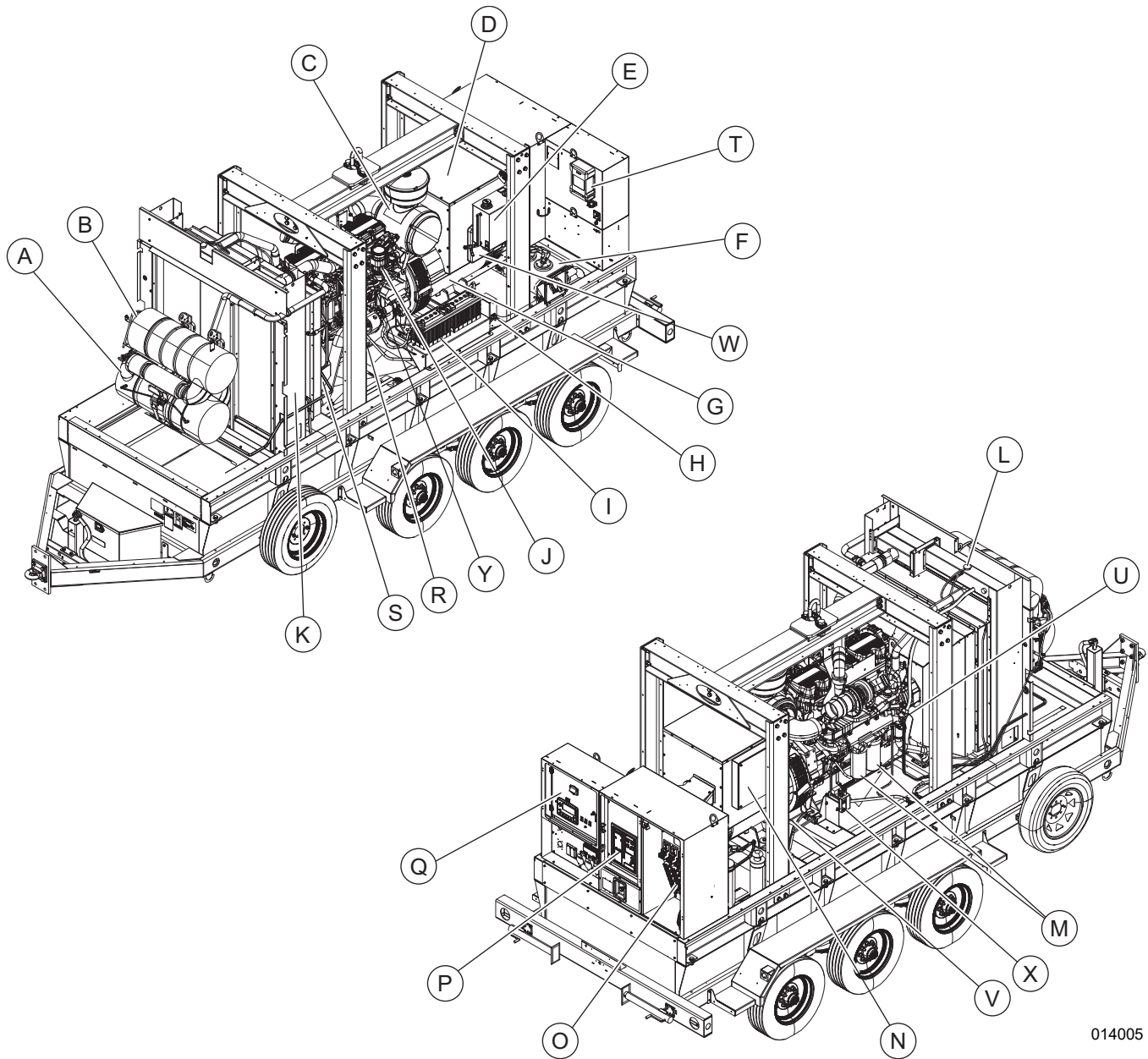

014005

**Figure 2-4. Interior Components**

- |  |   |
|--|---|
| <b>A</b> Diesel oxidation catalyst (DOC) and Diesel particulate filter (DPF) | <b>N</b> Link board panel                                       |
| <b>B</b> Selective catalytic reduction (SCR) module                          | <b>O</b> 3-phase AC power connection panel                      |
| <b>C</b> Air filter  | <b>P</b> Breaker panel  |
| <b>D</b> Generator box   | <b>Q</b> Control panel  |
| <b>E</b> Oil level maintainer kit (if equipped)—oil reservoir                | <b>R</b> fuel filters (behind engine charge alternator)         |
| <b>F</b> DEF tank  | <b>S</b> Engine charge alternator (behind engine fan)           |
| <b>G</b> Generator   | <b>T</b> Battery charger  |
| <b>H</b> Battery disconnect switch   | <b>U</b> Oil level indicator (dipstick)                         |
| <b>I</b> Batteries   | <b>V</b> AC junction box (if equipped)                          |
| <b>J</b> Crankcase ventilation (CCV) filter                                  | <b>W</b> Document holder  |
| <b>K</b> Radiator/charged air cooler   | <b>X</b> Oil level maintainer kit (if equipped)—maintainer body |
| <b>L</b> Radiator fill   | <b>Y</b> Fuel shutoff valve                                     |
| <b>M</b> Engine oil filters  |   |

## Component Locations—AC Distribution Panel

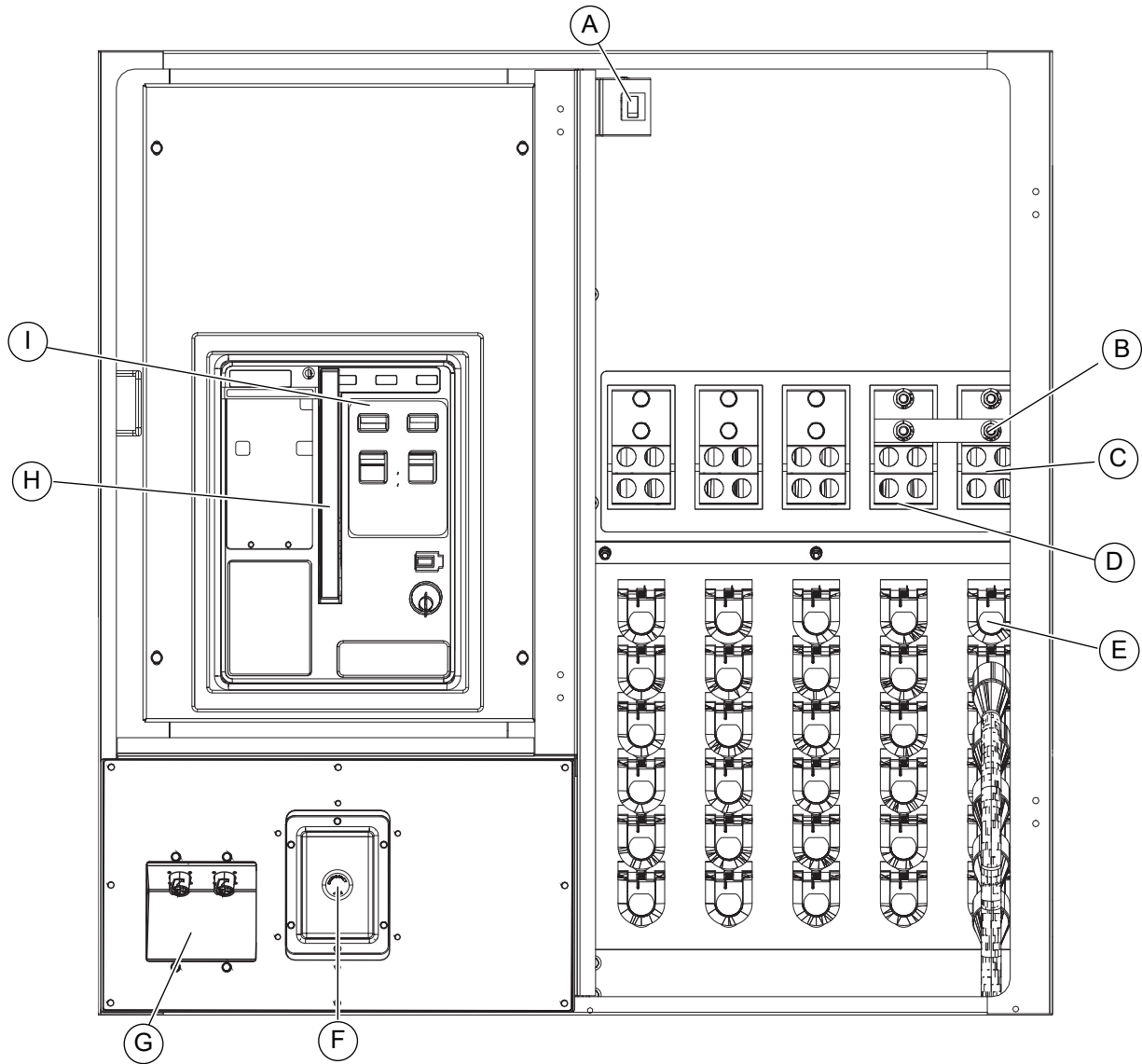

014006

**Figure 2-5. AC Distribution Panel Components**

- |   |   |
|---|---|
| <b>A</b> Lug door safety switch                           | <b>F</b> Emergency stop switch                      |
| <b>B</b> Neutral bonding bar                              | <b>G</b> Paralleling connection panel (if equipped) |
| <b>C</b> Ground terminal                                  | <b>H</b> Charging lever                             |
| <b>D</b> Terminal lug (4 locations)                       | <b>I</b> CLOSE-OPEN button                          |
| <b>E</b> Cam lock receptacle (30 locations) (if equipped) |   |

## Component Locations—Receptacle Panel

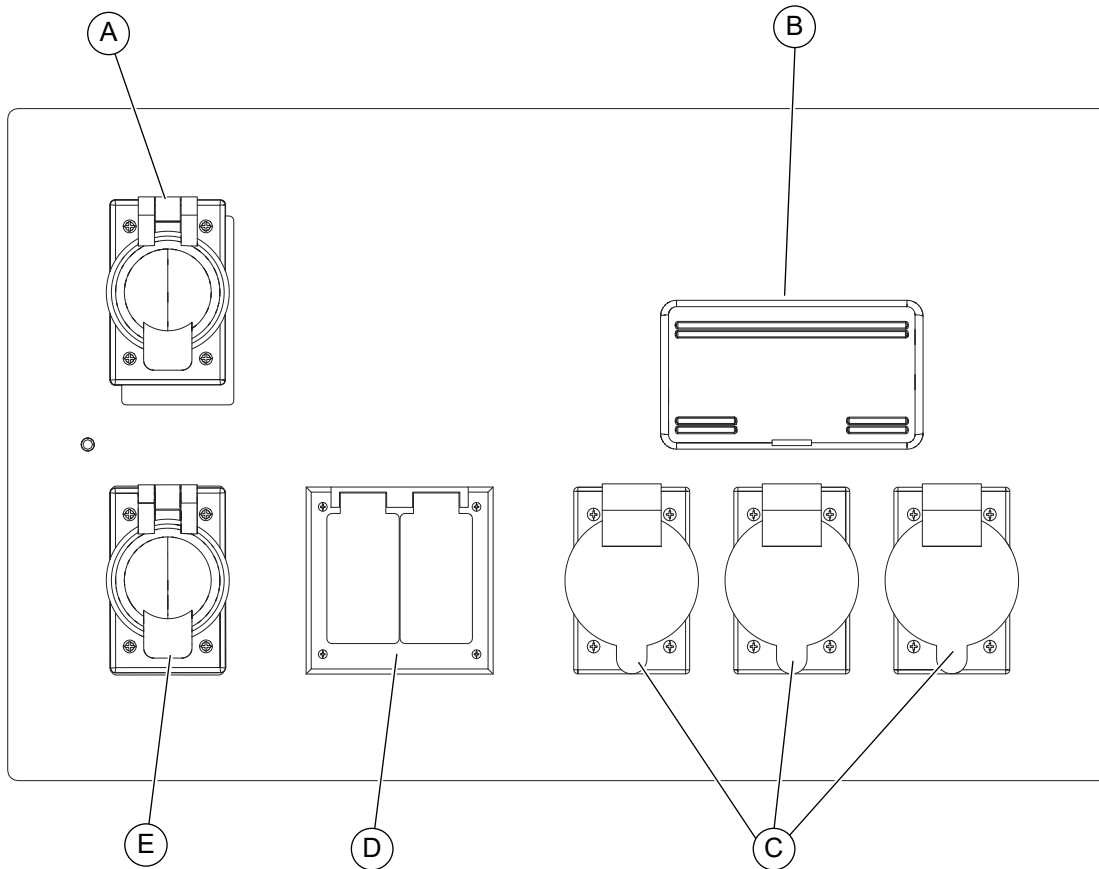

014007

**Figure 2-6. Receptacle Panel Components**

- |   |   |
|---|---|
| <b>A</b> 125 V, 15 A battery charger shore power plug (5-15P) (If equipped) | <b>D</b> 120 V, 20 A, GFCI, duplex outlets (NEMA 5-20R)                     |
| <b>B</b> Receptacle panel circuit breakers                                  | <b>E</b> 125 V, 30 A, winter heater shore power plug (L5-30P) (If equipped) |
| <b>C</b> 240 V, 50 A, 3 pole, twist-lock outlet (CS6369)                    |   |



## Component Locations—Control Panel

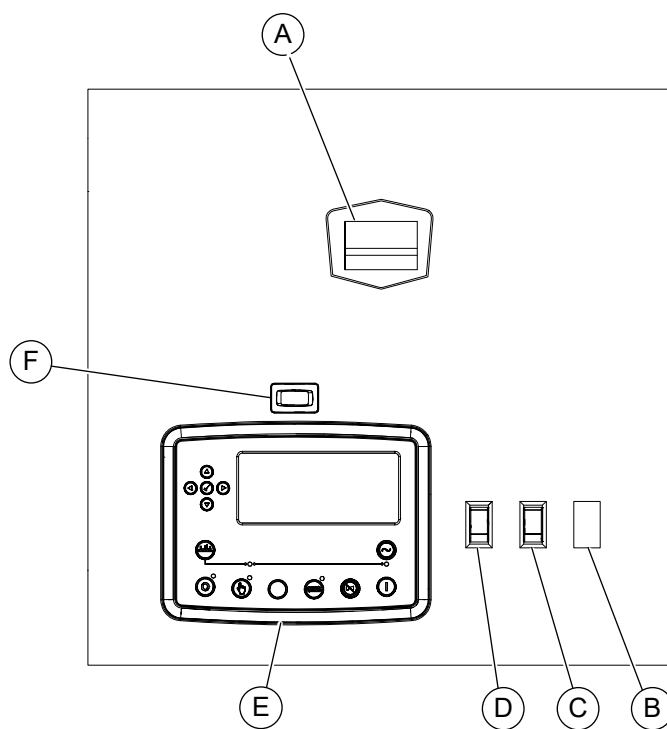

014008

**Figure 2-7. Control Panel Components**

- A** Panel light
- B** AUX fuel full switch
- C** RUN-IDLE switch

- D** Main lights switch
- E** Genset controller
- F** Hour meter

## Genset Controller

See [Figure 2-8](#). The genset controller displays real-time operational data, monitors functions of the generator and engine, shuts down the unit for certain fault conditions, displays fault data, and retains up to 250 unit performance events.

The controller is programmable. It can automatically start and stop the genset according to schedule, fault condition, or load demand.

**IMPORTANT NOTE: All units are equipped with the illustrated controller. Controller programming varies in accordance with unit equipment.**

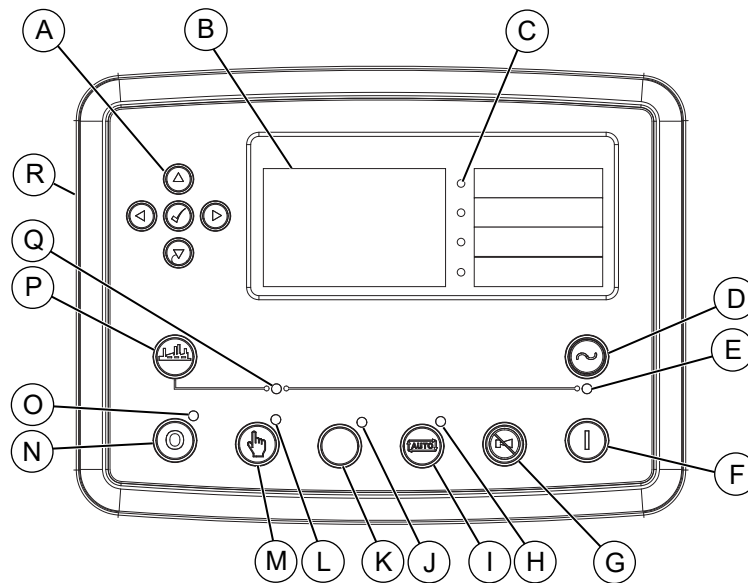

010417

**Figure 2-8. Genset Controller—Deep Sea® Model DSE8610 MKII**

- |  |   |
|--|---|
| <b>A</b> Navigation buttons              | <b>J</b> Positive air shutoff (PAS) valve test switch LED (if equipped) |
| <b>B</b> Screen                          | <b>K</b> PAS valve test switch (if equipped)                            |
| <b>C</b> Indicator LED (4 locations)     | <b>L</b> MANUAL Mode LED  |
| <b>D</b> Transfer to Generator button    | <b>M</b> MANUAL Mode button   |
| <b>E</b> Generator Available LED         | <b>N</b> Engine STOP/RESET Mode button                                  |
| <b>F</b> Engine START button             | <b>O</b> Engine STOP/RESET Mode LED                                     |
| <b>G</b> Alarm Mute and Lamp Test button | <b>P</b> Open Generator button  |
| <b>H</b> AUTO Mode LED                   | <b>Q</b> Open Generator LED   |
| <b>I</b> AUTO Mode button                | <b>R</b> RS232 serial port (not shown—controller backside)              |

### Genset Controller With Paralleling (If Equipped)

If the unit is equipped to run in parallel with other units, the controller is specifically programmed with paralleling functions.

Observe the following guidelines when operating units in parallel configuration:

- Paralleling-equipped units can be connected **ONLY** to other paralleling-equipped units.
- Before operating units in parallel configuration, verify each unit is operating correctly, in accordance with this manual.
- To verify the units intended for paralleling are appropriate for the load, contact Generac Mobile at 1-800-926-9768.

See [Operation](#) for unit paralleling setup and operation.

## (A) Navigation Buttons

See [Figure 2-9](#). Used to navigate the operator pages.

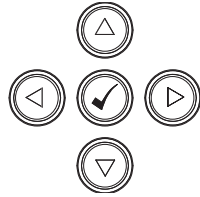

010418

**Figure 2-9. Navigation Buttons**

Navigate the operator pages as follows.

- ▶ View next
- ◀ View previous
- ▲ Scroll up current
- ▼ Scroll down current
- ✓ Select highlighted item

## (B) Controller Screen

The controller screen displays various operational data for unit monitoring, diagnosing, and troubleshooting. See [Operator Pages](#) for more information.

## (C) Indicator LEDs

See [Figure 2-10](#). Each LED indicates a condition that impedes normal unit function.

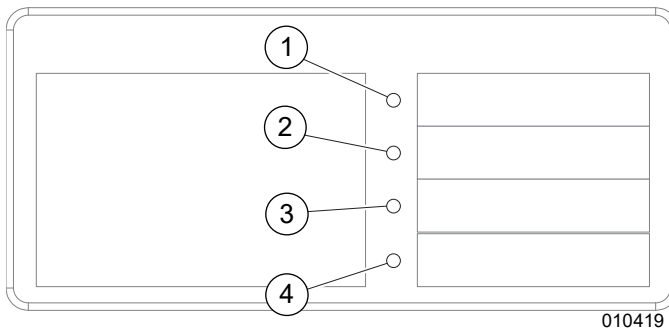

010419

**Figure 2-10. Indicator LEDs**

If an indicator LED is illuminated, resolve the condition to restore normal unit function, as described in table below.

**NOTE:** When a condition is resolved, the corresponding indicator LED switches off.

### (1) Low Load indicator LED.

- Indicates genset has operated at less than 30% capacity for more than 15 minutes.
- Resolve by increasing electrical load. If unable to operate genset at more than 30% load, use a smaller generator.

### (2) Lug Door Open indicator LED.

- Indicates lug-box door is open.
- Resolve by closing lug-box door. If condition remains unresolved, inspect lug-box door safety switch for proper operation.

### (3) Emergency Stop indicator LED.

- Indicates Emergency Stop switch is active (pushed in).
- Resolve by deactivating (pulling out) Emergency Stop switch.

### (4) Shutdown indicator LED.

- Indicates a shutdown alarm is present.
- Resolve by resolving shutdown condition.

**NOTE:** If unable to resolve a condition as recommended, contact a GMASD.

## (D) Transfer to Generator Button

Only applies to MANUAL mode.

Controls operation of generator load switch, when the generator is available.

**NOTE:** In units equipped with a manual breaker, this function is not available.

Status is indicated by the Close Generator LED.

## (E) Close Generator LED

- When illuminated, the main circuit breaker is closed, and cam locks and lugs are enabled.
- When not illuminated, the main circuit breaker is open, and cam locks and lugs are disabled.

## (F) Engine Start Button

When STOP/RESET mode is active, the Engine Start button switches on the engine ECU but does not start the engine. Uses in this context are to check status of the CAN communication and to prime the engine.

When MANUAL mode is active, the Engine Start button starts the generator.

**NOTE:** In AUTO or STOP mode, the Engine Start button activates the ECU.

## (G) Alarm Mute and Lamp Test Button

Stops the audible alarm and illuminates functional controller LEDs.

To test the LEDs, press and hold button. All LEDs illuminate. When button is released, the LEDs switch off.

**NOTE:** If an LED does not illuminate when button is pushed, the LED is not functioning.

## (H) AUTO Mode LED

- When illuminated, AUTO mode is active.
- When not illuminated, AUTO mode is not active.

## (I) AUTO Mode Button

Switches the mode to AUTO. See [Controller Modes](#) for important guidelines.

Status is indicated by the AUTO Mode LED.

---

### (J) PAS valve test switch LED (if equipped)

When illuminated, PAS test is in progress.

### (K) PAS valve test switch (if equipped)

When PAS test is active, the PAS is cycled once for 15 seconds to verify function. Press and hold test button until message is displayed on screen. Release button and allow PAS to cycle.

### (L) MANUAL Mode LED

- When illuminated, MANUAL mode is active.
- When not illuminated, MANUAL mode is not active.

### (M) MANUAL Mode Button

Switches the mode to MANUAL. See [Controller Modes](#) for important guidelines.

Status is indicated by the MANUAL Mode LED.

### (N) Engine STOP/RESET Mode Button

Switches the mode to STOP. See [Controller Modes](#) for important guidelines.

Status is indicated by the STOP/RESET Mode LED.

### (O) Engine STOP/RESET Mode LED

- When illuminated, STOP mode is active.
- When not illuminated, STOP mode is not active.

### (P) Open Generator Button

The Open Generator button is only active in the Manual Mode and allows the operator to open the generator load switch when a motorized breaker is used. Pressing the Open Generator button when the Generator is on load, the generator main circuit breaker switch is open.

**NOTE:** In units equipped with a manual breaker, either limited or no function is available.

Status is indicated by the Open Generator LED.

### (Q) Open Generator LED

- When illuminated, cam locks and lugs are disabled.
- When not illuminated, cam locks and lugs are enabled.

## Controller Modes

**NOTE:** See [Operation](#) for instructions on changing controller mode.

### MANUAL Mode

MANUAL mode is distinguished by full operator control of unit start-up and shut-down functions, and by full operator control of generator load and unload functions.

### AUTO Mode

AUTO mode is distinguished by automation of unit start-

up and shut-down functions, and by automation of generator load and unload functions.

AUTO mode utilizes the remote start connections. For remote starting procedures, see [Operation](#).

AUTO mode utilizes a programmed schedule, which can be modified.

**NOTE:** To modify the AUTO mode programmed schedule, use the Deep Sea Configuration Suite software.

### STOP/RESET Mode

STOP/RESET mode is distinguished by the following:

- Unloads the generator.
- Clears active alarms—if alarm conditions have been resolved.
- Shuts down the unit.
- Deactivates the Engine Start button.
- Stops all AUTO mode automation (if applicable).
- Controller power remains ON.

## Operator Pages

Operator pages display various data for unit monitoring, diagnosing, and troubleshooting. The pages are:

- Home page
- Status page
- Engine page
- Generator page
- Alarm page
- ECU DTC page
- Event Log page
- Serial Port page
- Program File Information page
- About page

**NOTE:** Operator pages are available after normal unit start-up.

**NOTE:** Operator pages are view-only. No settings can be added, modified, or deleted.

### Home page

When no other page has been selected, or after a period of controller inactivity, the Status page automatically displays. This is the Home page.

**NOTE:** The Home page varies, according to the state of the unit.

- See [Figure 2-11](#) for Home page when engine is stopped.

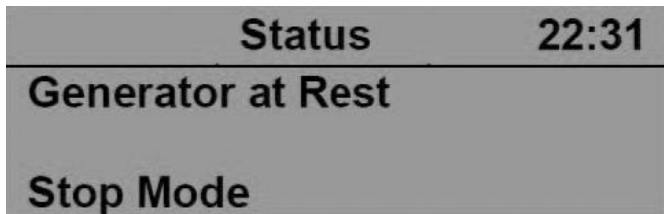

014030

**Figure 2-11. Home Page—Engine Stopped**

- See [Figure 2-12](#) for home page when engine is running.

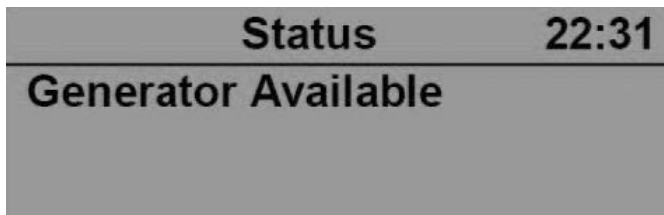

014029

**Figure 2-12. Home Page—Engine Running**

#### Generator Page

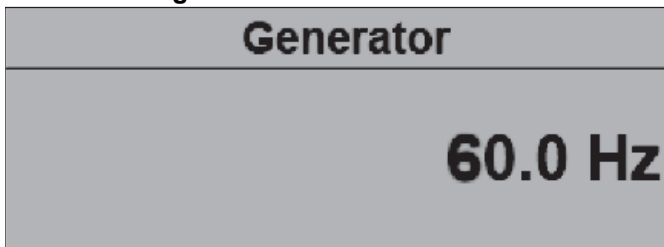

010422

**Figure 2-13. Generator Page**

The Generator page displays the following generator data, in real time (press ▲ or ▼ to scroll).

- Voltage (ph-N)
- Voltage (ph-ph)
- Frequency
- Current (A)
- Load ph-N (kW)
- Total load (kW)
- Load ph-N (kVA)
- Total load (kVA)
- Single phase power factors
- Power factor average
- Load ph-N (kvar)
- Total load (kvar)
- Accumulated load (kWh, kVAh, kvarh)
- Loading scheme
- Phase rotation
- Nominal

- Active configuration

**NOTE:** The list in the previous column varies according to generator make, model, and features.

**NOTE:** As possible, distribute electrical loads equally among generator lines. Minor load imbalances (10% or less) usually do not cause problems. When loading generator, observe the load (amperage) on each line.

#### Alarms Page

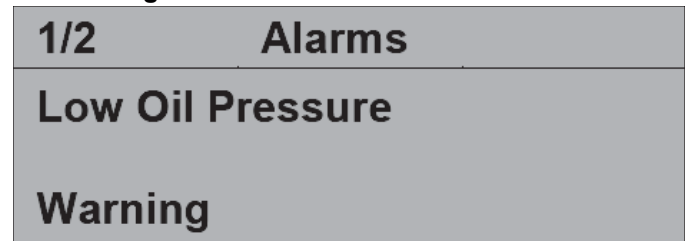

010423

**Figure 2-14. Alarm Page**

The Alarms page displays active warnings and active alarms, including engine DTCs.

#### ECU DTC Page

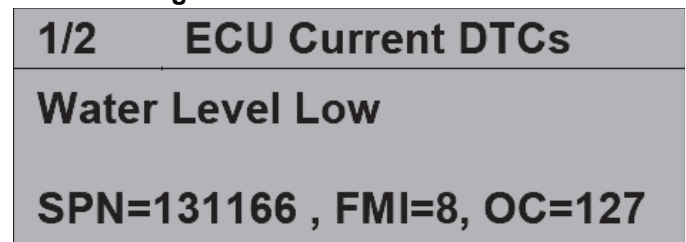

010424

**Figure 2-15. ECU DTC Page—Current DTCs**

The ECU Current DTC page displays active ECU DTCs. Press ► to view previous ECU DTCs.

**NOTE:** See engine manual for information on ECU DTCs.

**NOTE:** All DTCs display on the ECU DTC page. Some DTCs also display in the Event Log, with similar descriptions.

#### Event Log Page

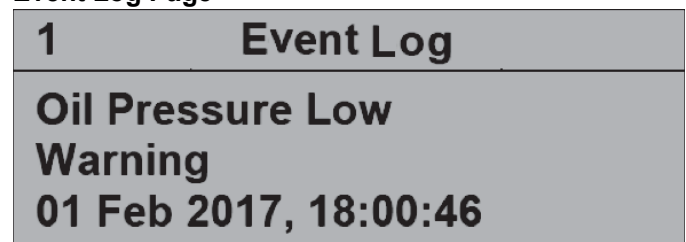

010425

**Figure 2-16. Event Log Page**

The Event Log page displays current and previous alarms.

- Event Log capacity is 250 alarm events. After 250 events are logged, each new event overwrites the oldest.
- Only alarms are logged.
- Newest event displays at top of log; oldest at bottom.

### Serial Port Page

The Serial Port page displays information about the RS232 serial port, which enables data transfers. If an external modem is connected to the serial port, modem information also displays.

**NOTE:** The Serial Port page display may vary, in accordance with controller configuration.

See [Figure 2-17](#). If a modem is connected to the controller, *Modem* displays, as illustrated.

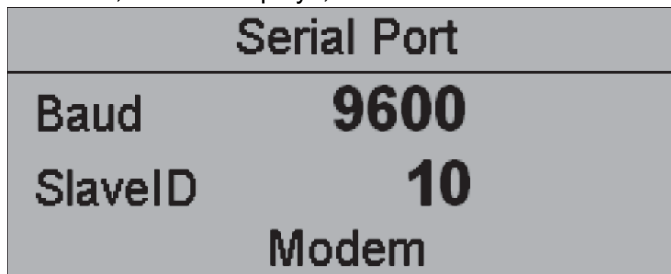

010426

**Figure 2-17. Serial Port Page. If modem is not connected, RS232 displays in place of Modem.**

See [Figure 2-18](#). When the controller can accept a data transfer, *Modem Ready* displays, as illustrated.

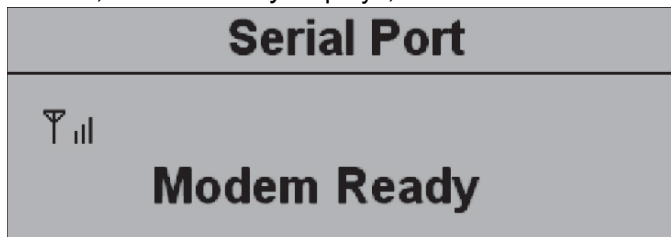

010427

**Figure 2-18. Serial Port Page—Modem Ready**

### Program File Information Page

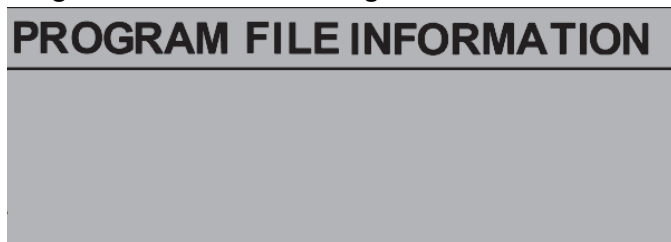

014037

**Figure 2-19. Program File Information Page**

The Program File Information page displays the following controller information.

- Controller model unit
- Program file name

- Program PN
- Program version

### About Page

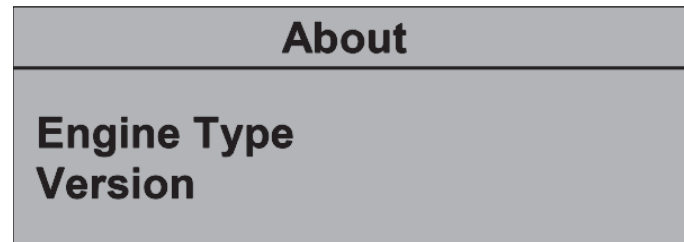
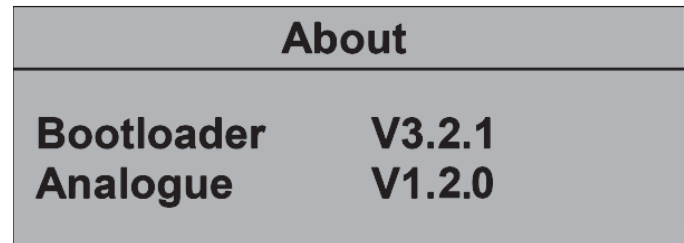
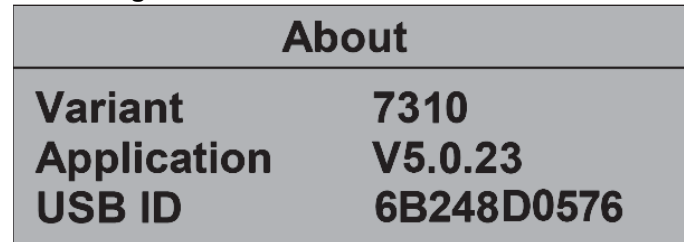

010429

**Figure 2-20. About Page**

The About page displays various general information about the unit and controller, as illustrated.

### Maintenance Alarms

Maintenance alarms indicate a regular-maintenance service interval is expired. To resolve the condition, perform the indicated service, then re-set the corresponding service interval.

To re-set a service interval:

1. Display the Engine page.
2. Scroll (▲ or ▼) until the appropriate service interval is highlighted.

**NOTE:** The expired interval displays on the Alarm page.

3. Press and hold the Engine STOP/RESET Mode button until **###\* hr service** changes to **0 hr service**.

*\*A number displays. The value varies according to what service interval is highlighted.*

## Fuel System

Standard units are equipped with the following fuel system components:

- Single wall fuel tank
- Engine fluid containment
- Engine fluid containment sensor

### Fuel Tank

See [Figure 2-21](#) for fuel tank components.

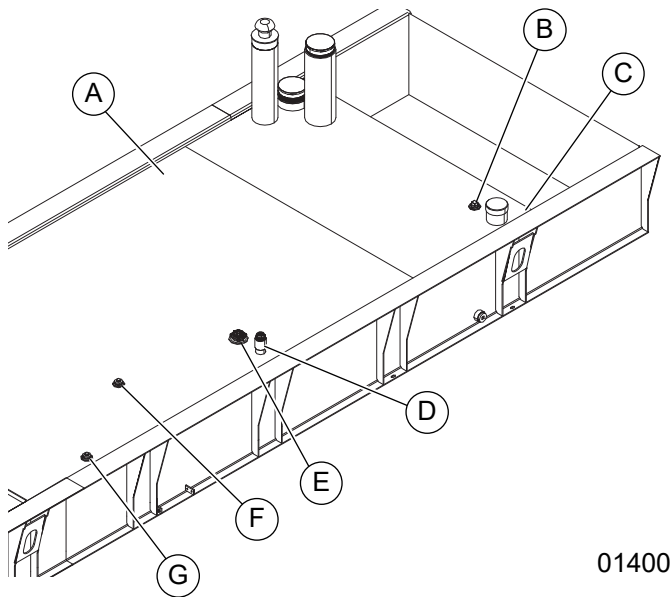

**Figure 2-21. Fuel Tank**

- A** Single-wall or double-wall fuel tank
- B** Auxiliary fuel tank connection (if equipped)
- C** Engine fluids (oil, coolant, and DEF) leak detection sensor
- D** Fuel leak detection sensor (Rupture basin alarm) (if equipped)
- E** Fuel level sender
- F** Fuel supply
- G** Fuel return

## Engine Aftertreatment Monitoring

This section describes the indicators that display on the After Treatment Status page of the Engine tab.

[Figure 2-22](#). This unit is equipped with an exhaust gas recirculation cooler (EGR), diesel oxidation catalyst (DOC), diesel particulate filter (DPF), and selective catalyst reduction system (SCR), to meet Tier 4 Final EPA emissions standards.

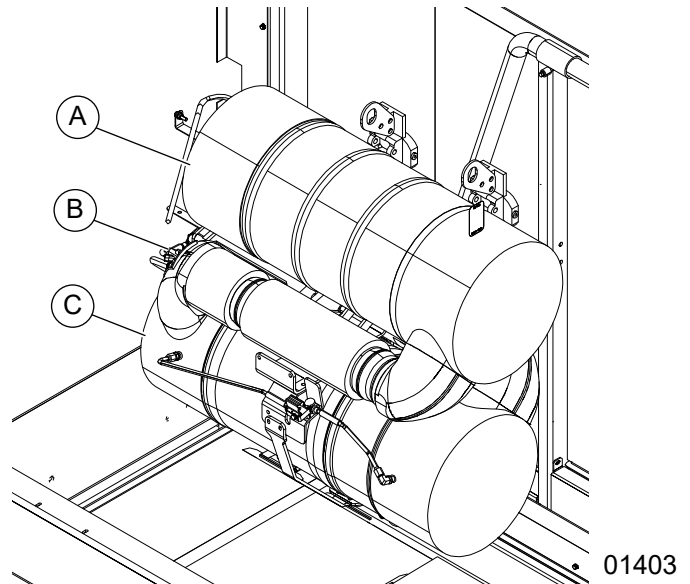

**Figure 2-22. Aftertreatment System**

- A** SCR module
- B** Spark plug for after burner system
- C** DOC and DPF









To access the After Treatment Status status page:

1. Press an arrow button (▲, ►, ▼, or ◀) to access the Maintenance pages.
2. When on the Engine tab, press ▼ to scroll through the pages until the After Treatment Status page displays.

Four areas of the After Treatment Status page communicate information to the operator. The areas and the indicators that appear in those areas are explained here:

- **HEST Lamp (High Exhaust System Temperature):** This area displays the regeneration underway indicator above the words HEST LAMP - SOLID when the unit is in the process of the exhaust catalyst. During the regeneration process, the exhaust temperature will be very high.
- **DPF Regeneration Lamps:** Depending upon the Engine Type selected in the module's configuration, the Engine section may include the DPF Regeneration Lamps page. This page contains icons to show the status of various ECU functions, some of which are applicable to Tier 4 engine requirements. The icons flash at different rates to show the status of the ECU function, refer to the engine manufacturer for more information about this.



Icon	Fault	Description
	ECU Amber Alarm	The module received an Amber fault condition from the engine ECU..
	ECU Red Alarm	The module received a Red fault condition from the engine ECU.
	DPF Active	The module received a fault indication from the engine ECU informing that the Diesel Particulate Filter is active.
	DPF Inhibited	The module received a fault indication from the engine ECU informing that the Diesel Particulate Filter has been inhibited.
	DPF Stop	The module received a fault indication from the engine ECU informing that the Diesel Particulate Filter has been stopped.
	DPF Warning	The module received a fault condition from the engine ECU informing that the Diesel Particulate Filter has a fault condition.
	HEST Active	The module received a fault indication from the engine ECU informing that the High Exhaust System Temperature is active.
	DEF Low Level	The module received a fault condition from the engine ECU informing that the Diesel Exhaust Fluid Low Level is active.
	SCR Inducement	The module received a fault indication from the engine ECU informing that the Selective Catalytic Reduction Inducement is active.

See [Figure 2-23](#) for examples.

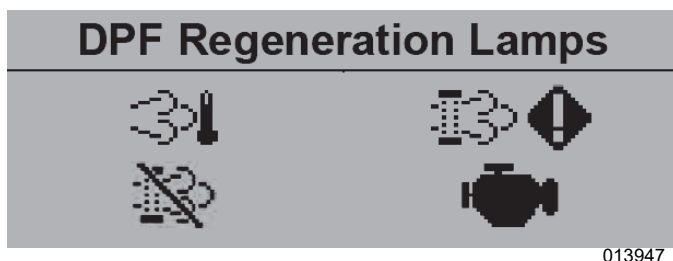

013947

**Figure 2-23. Icons—On-Screen Examples**

- **Diagnostic Codes & Events:** This area will display the engine alarm indicator above the words ALARM - SOLID when an alarm condition occurs. This area displays different text depending upon which alarm condition occurs.

See [DOC, SCR, and DPF Cleaning Operations](#) for more information on the operation of auto exhaust filter regeneration and service regeneration.

## Alternator

### Standard Alternator

- Excitation: Permanent magnet generator (PMG)
- Voltage regulation: DSE A109 automatic voltage regulation (AVR). See [Voltage Regulator](#).
- Voltage fine tuning: See [Fine Tuning the Voltage](#).

### Optional Alternators (If Equipped)

- SuperStart alternator: This unit may be equipped with a SuperStart alternator.
- VFLEX (600 V) alternator: This unit may be equipped with a VFLEX alternator.



## Cold Weather Starting Aids (If Equipped)

### Component Locations

See [Figure 2-24](#). This unit may be equipped with one or more starting aids for cold weather operation.

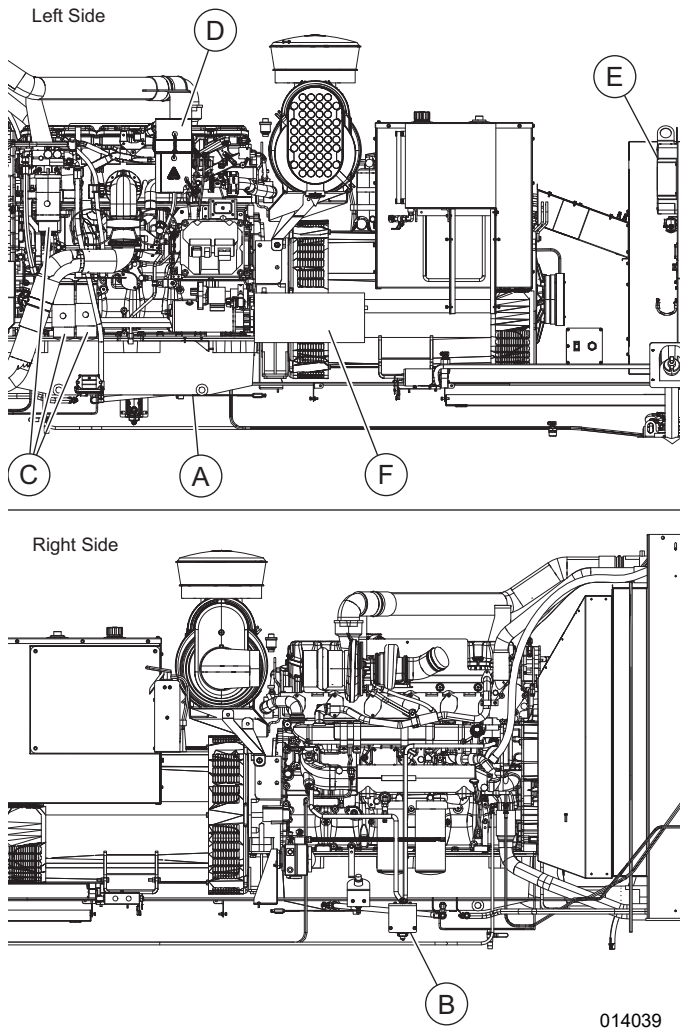

**Figure 2-24. Parts Removed for Clarity**

#### (A) Oil Pan Heater

1,000 W, 120 VAC. Requires optional shore power inlet (see receptacle panel).

#### (B) Block Heater

2,250 W, 120 VAC. Requires optional shore power inlet (see receptacle panel).

#### (C) Fuel Filter Heaters (×3)

50 W, 24 VDC.

#### (D) Crankcase Ventilation Heater

54 W, 24 VDC.

#### (E) 30 A Battery Charger

Requires optional shore power inlet (see receptacle panel). See [Operation](#) for more information.

#### (F) 1,100 CCA Batteries

More cranking power for extreme cold.

#### (Not Shown) 60/40 Coolant

60% ethylene glycol mixture lowers freezing point of coolant.

### Recommendations

**⚠ DANGER**

Explosion. Do not use ether when starting an engine equipped with glow plugs or an air intake heater. Doing so could cause an explosion, which will result in death or serious injury. (000583)

**IMPORTANT NOTE:** The use of correct grade oil is critical to achieving adequate cold weather cranking speed. Synthetic oils have improved flow at low temperatures. see [Engine Oil Recommendations](#).

Starting aids may be required under the following conditions:

- Cold weather.
- When starting equipment with high parasitic loads during cranking and start acceleration to idle.
- When using unit above 5,000 ft (1,500 m) altitude.

See [Figure 2-25](#). Recommended cold-weather packages vary in accordance with expected temperatures.

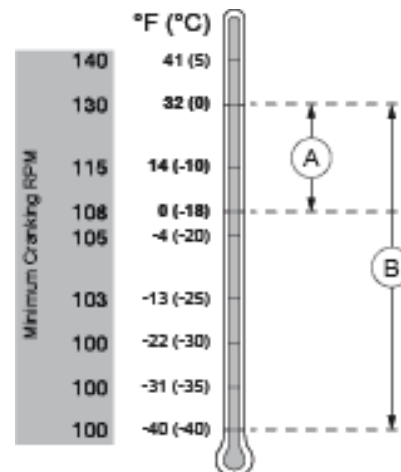

**Figure 2-25. Recommended Packages**

#### (A) From 32 to 0 °F (0 to -18 °C)

Standard Package is recommended.

#### (B) From 32 to -40 °F (0 to -40 °C)

Extreme Package is recommended.

---

**NOTE:** See [Table 2-1](#) for components in each package.

**Table 2-1.**

Component	Standard Package	Extreme Package
Block heater	◆	◆
CCV heater	◆	◆
Battery charger	◆	◆
Fuel filter heater	◆	◆
Oil heater	◆	◆
Dual 4D batteries		◆
60/40 coolant		◆

# Section 3: Operation

## Overview

The engine can be started in low-idle or at normal operating speed (1,800 rpm). In cold weather, it is recommended to start the engine in low-idle condition, and idle for up to one minute. That allows the engine oil to heat up before increasing engine speed and applying load. If the engine is in an idle condition for an extended period, the ETM may drive a higher engine speed to generate more heat and activate a regeneration.

**IMPORTANT NOTE: The breaker cannot be closed while engine is in low-idle condition, as such load cannot be applied.**

Low idle speed is 1,100 rpm.

## Prestart Checklist

All items in the prestart checklist must be completed before starting the unit. This checklist applies to both manual and remote starting of the unit.



### ⚠️ WARNING

Consult Manual. Read and understand manual completely before using product. Failure to completely understand manual and product could result in death or serious injury. (000100a)

### ⚠️ WARNING

Equipment damage. Do not attempt to start or operate a unit in need of repair or scheduled maintenance. Doing so could result in serious injury, death, or equipment failure or damage. (000291)

- Read and understand all safety guidelines. See [Introduction and Safety](#).
- Perform daily maintenance and other periodic maintenance. See [Maintenance](#).
- Verify the unit is level.
- Verify no water is inside, on, or near the unit. Dry if needed.
- Ground the unit in accordance with all applicable local, state, and National Electrical Code (NEC) guidelines.
- Verify all circuit breakers are OFF (O).
- Inspect all electrical cords. Repair or replace any that are cut, worn, or bare.
- Verify oil, coolant, DEF, and fuel levels are correct, in accordance with the OEM engine manual.
- Verify battery connections are secure.
- Check engine fan belt tension and condition.

- Check engine fan belt guard.
- Check engine exhaust system for loose or rusted components.
- Verify all covers are in place and secure.
- Verify all electrical connections at the connection lugs, if equipped, are tight and wired correctly.
- Verify the link board is set to the desired voltage and locked.
- Verify the emergency stop switch is pulled out.
- Verify the radiator and surrounding shroud are clear of debris.
- Turn the battery disconnect switch ON.
- Open the fuel shutoff valve.

## Cold Weather Operation

In cold environments, units equipped with starting aids are recommended. See [Cold Weather Starting Aids \(If Equipped\)](#).

When starting a unit equipped with starting aids, observe these guidelines:

- Follow supplier instructions for starting aids provided on engine.
- An optional 24 VDC, 30 A battery charger can be configured with the machine if needed and is recommended if machine is equipped with fuel filter heater or CCV heater. The shore power inlet receptacle (120 V, 15 A [5-15P]) can be located on the convenience receptacle panel. Shore power will be required to utilize on-board battery charger. When engine has started, the inlet receptacle can be disconnected as charger will no longer be needed if engine continues to run.

**IMPORTANT NOTE: In cold temperatures, with the engine off, the DC-powered heaters for cold starting and cold-operation will deplete the engine-starting batteries if the batteries are not being charged by the optional on board battery charger.**

**NOTE:** If alternate battery charger is being used please see [Using An External Battery Charger](#) for correct charger connection.

- An optional coolant heater and oil pan heater can be configured to aide cold weather starting. The shore power inlet receptacle (125 V, 30 A) can be located on the convenience receptacle panel. Shore power will be required to utilize on-board coolant and oil pan heater. If machine has been stored at -40F (-40C) temperatures for 8 hours more, preheat times up to 6 hours might be required to provide adequate heating to coolant

and oil. Preheat time is reduced to 2 hours if ambient temperatures have not been colder than -4F (-20C). These heaters will cycle on and off as needed during preheat cycle. When engine has started, the inlet receptacle can be disconnected as heater will no longer be needed if engine continues to run.

- Optional fuel filter heaters (x3) can be configured with the machine to aide in cold weather starting and cold weather operation. These heaters are powered via the battery circuit (24 VDC). These heaters are equipped with a thermo-switch for automatic heater activation when ambient temperatures drop below the switch threshold. The battery disconnect switch must be switched to the ON position for these heaters to work. The machine must also be configured with a 24 VDC, 30 A battery charger to ensure maximum battery performance and heater operation.
- Optional crankcase ventilation heater can be configured with the machine to aide in cold weather operation. This heater is powered via the battery circuit (24 VDC). This heater is equipped with a thermo-switch for automatic heater activation when ambient temperatures drop below the switch threshold. The battery disconnect switch must be switched to the ON position for these heaters to work. The machine must also be configured with a 24 VDC, 30 A battery charger to ensure maximum battery performance and heater operation.
- Standard 50/50 coolant can be used down to 0 °F (-18 °C). If continued operation below 0 °F (-18 °C) is likely, it is recommended to use 60/40 coolant blend for optimal machine performance during cold weather operation.
- For more information on cold weather operation, see your local GMASD.

### Using An External Battery Charger



#### CAUTION

Equipment damage. Do not make battery connections in reverse. Doing so will result in equipment damage.

(000167a)

See [Figure 3-1](#). A 24 VDC battery charger can be connected to the batteries, to aid in cold weather starting. ALWAYS use heavy-duty jumper cables.

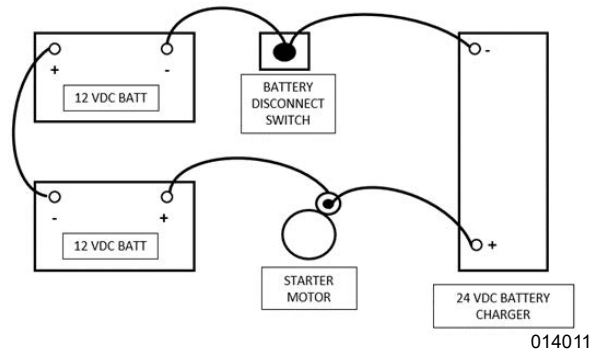

**Figure 3-1. Connecting Battery Charger**

1. Connect battery charger to a power source.
2. Switch the battery disconnect switch to ON, completing the circuit of the batteries connected in series. This will allow charging of both batteries on the generator.
3. Connect the POSITIVE (+) cable of the battery charger to the positive post of the battery that is connected directly to the (+) post of the starter.
4. Connect the NEGATIVE (-) cable of the battery charger to the grounding lug on the frame located directly below the BDS as seen in the image.
5. Turn the charger to the correct voltage setting and charging current.
6. Start the engine. Disconnect jumper cables immediately after engine starts.

**NOTE:** To avoid sparks, do not allow free ends of jumper cables to touch metallic conductive material.

### Using Two-Position Link Board



#### WARNING

Electrocution. Potentially lethal voltages are generated by this equipment. Render the equipment safe before attempting repairs or maintenance. Failure to do so could result in death or serious injury.

(000187)

**IMPORTANT NOTE:** Never attempt to open link board panel when engine is running. There is a safety switch that will shunt trip breaker and shut down generator if panel is removed.

The two-position link board mechanically configures the generator main windings.

This unit is equipped with one of three multi-voltage alternators capable of achieving up to 600 VAC. In addition to the link board, a two-position toggle switch can be used to select other voltages. A large decal on the link board cover panel details the proper connections for selected voltages.

1. Shut down the unit. See [PAS, Installation, Operation & Testing \(if equipped\)](#).

2. Remove fasteners from link board cover panel.
3. Loosen nuts securing link board plate to panel.
4. Position link board according to the correct configuration, to obtain the desired output voltage.
5. Tighten nuts 40 ft-lb (54.2 Nm).
6. See [Figure 3-2](#) and [Table 3-2](#). Verify toggle switch (A) is in correct position for the desired voltage.

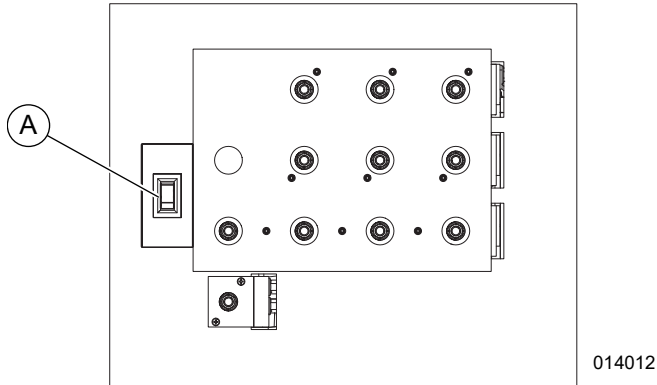

**Figure 3-2. Link Board**

**Table 3-2. Link Board Positions, Voltage Settings**

		Rocker Switch	
		Up	Down
Link Board	Up	240 VAC	208 VAC
	Down	600 VAC*	480 VAC

\* If equipped. If unit does not have 600 VAC capability, it will default to 480 VAC.

7. Install link board cover panel. Tighten bolts to 10 ft-lb (13.6 Nm).

## Lockout Function

The link board is equipped with a lockout mechanism. When engaged, the switch is locked in place, preventing configuration changes. If an attempt is made to access the link board, the controller will shunt trip the breaker and stop the engine.

## 3-Way Fuel Valve (If Equipped)

The unit may come equipped with a 3-way fuel valve to provide longer autonomous running with the use of a larger auxiliary fuel tank. The placement of the auxiliary fuel tank should be directly adjacent to the generator. Avoid any dips or traps in the line between the generator and the auxiliary fuel tank. This will help to purge air from the circuit and improve the flow of fuel to the engine. The fuel tank should be on the same level ground/platform that the generator sits on. The maximum pumping height without an additional lift pump installed is 1.5m (60"). Fuel hoses longer than 15 feet coming out of the base

frame rail can cause higher restrictions in the supply line resulting in performance issues, engine power derates and/or fault codes due to high fuel pressure restrictions. A lift pump can be installed to push fuel from an external tank if a longer supply hose is required to connect the auxiliary tank, it shall have a maximum supply pressure of 100 kPa (14.7 PSI) and a flow capacity up to 127 GPH (480 LPH). The maximum pressure restriction at the filter head shall not be greater than -27 kPa. Pressure restrictions greater than this can cause permanent damage to the engine fuel system. The 3-way valve can then be rotated to the correct position to allow use of either the main tank or auxiliary tank. The third position will close the valve for both tanks. When using the auxiliary fuel tank, the main fuel tank must be maintained above a 15% fuel level. If the main tank fuel level is below 15%, a low fuel level warning will be displayed on the controller independent of the fuel level in the auxiliary fuel tank. If the fuel level in the main tank is below 5%, the engine will not start due to the low fuel level shut down alarm.

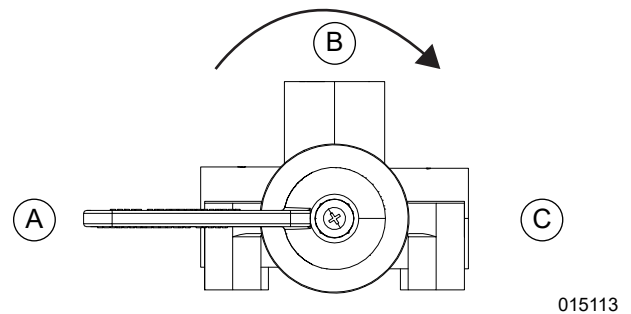

**Figure 3-3. 3-Way Fuel Valve**

- A Main Tank Supply
- B Aux Tank Supply
- C Valve Closed

## Fuel System Priming

When switching the 3-way valve to use the auxiliary fuel tank, the fuel system will need to be primed prior to starting the engine. This is to ensure there is adequate fuel in the lines and the air has been purged from the circuit. The priming function can be performed using the Perkins Service Tool or via the control panel. Please refer to the engine manual for instructions on how to use the Perkins Service Tool. Alternatively, the fuel system priming function can be performed by simultaneously pressing and holding for 3 seconds the "MANUAL MODE" and "ALARM MUTE" buttons on the controller. The fuel priming will start and run for 2 minutes. The engine must be



off, the controller in STOP mode and the battery disconnect switch must be on. The engine cannot be started while the priming function is running.

## Manually Starting the Unit



### **⚠ DANGER**

Asphyxiation. Running engines produce carbon monoxide, a colorless, odorless, poisonous gas. Carbon monoxide, if not avoided, will result in death or serious injury. (000103)



### **⚠ WARNING**

Hot Surfaces. When operating machine, do not touch hot surfaces. Keep machine away from combustibles during use. Hot surfaces could result in severe burns or fire. (000108)



### **⚠ WARNING**

Fire risk. Fuel and vapors are extremely flammable. Do not operate indoors. Doing so could result in death, serious injury, or property or equipment damage. (000281)

To start the generator in MANUAL mode:

1. Switch the battery disconnect switch to the ON position.

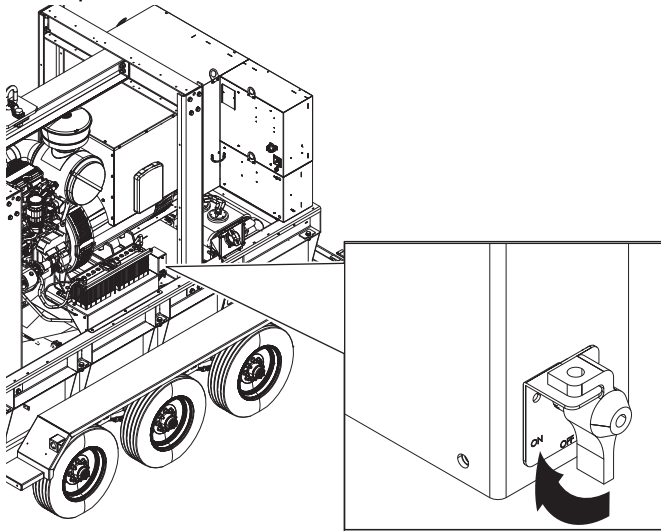

014014

**Figure 3-4. Battery Disconnect Switch**

**NOTE:** See [Figure 3-5](#). The Home page displays when the controller is ON, and no other page has been selected. The controller is in STOP mode.

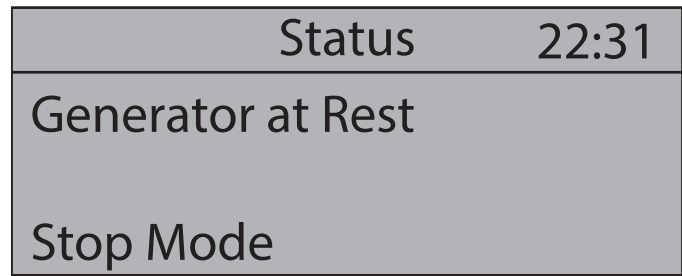

011608

**Figure 3-5. Home Page**

2. Press the AUTO/MANUAL mode button to start MANUAL mode.

**NOTE:** The controller can be started from any page when MANUAL mode is active.

3. Press the green Engine START (I) button on the controller to initiate the engine startup process. The unit starts if there are no engine faults preventing the unit from starting.

**NOTE:** It may take a few seconds for the engine to run smoothly and reach operating speed. During this time, a voltage displays, different from the voltage set on the voltage selector switch.

4. If the engine does not start after the first cranking attempt, the engine pauses for 15 seconds, allowing the starter to cool. The controller displays MANUAL MODE - CRANK REST. The engine will attempt to start twice more, for a total of three crank cycles.
5. If the engine does not start and run after three crank cycles, the controller displays the fail to start alarm. The starting sequence can be repeated after the starter has had a minimum of two minutes to cool. Press the ENTER button to clear the alarm and reset the controller.

**NOTE:** If the engine is equipped with glow plugs or air heater, the controller will allow time for preheating before cranking engine. Some engines may not have a preheating cycle and as such will skip preheat cycle.

6. When the engine starts, it behaves according to the position of the low-idle switch (LIS):
  - If the LIS is in the IDLE position, the engine continues to idle at 1,100 rpm.
  - If the LIS is in the RUN position, the engine idles for 10 seconds, then accelerates to operating speed (1,800 rpm).

**NOTE:** In cold weather, it is recommended to start the engine in low-idle condition, and idle for up to one minute. The engine may hunt or change speeds until operating speed is reached.

7. Before applying load, inspect the generator for excessive noise or vibration, and for coolant, oil, DEF, and fuel leaks.
8. Verify the AC output voltage is correct. See [Fine Tuning the Voltage](#).
9. Verify the frequency (Hz) is correct on the Generator page. The frequency should read approximately 60 Hz with no loads connected to the generator, depending on the type of engine governing used.
10. Switch the main circuit breaker to ON (I), then add any loads attached to the receptacles by switching the respective circuit breaker to the ON (I) position. A slight change in engine sound when a load is applied to the unit is normal.

## AUTO (Remote) Starting the Unit

**IMPORTANT NOTE:** Before starting in AUTO mode, review [Prestart Checklist](#) and [3-Way Fuel Valve \(If Equipped\)](#). Follow all safety warnings and review all information on isolating the generator with a transfer switch, if the unit will be used as a standby power source. See [Changing Exercise Timers](#), then proceed in accordance with this section.

Use AUTO (remote start) mode to start from somewhere other than the control panel by using a transfer switch. AUTO mode is the normal setting when the unit is being used as a standby power source.

1. Start the unit in MANUAL mode at least once, to verify correct engine operation.
2. Check the remote start circuit:
  - Remove wires from the remote start terminal block.
  - Change controller mode to AUTO. See [Switching Controller Mode](#).
3. Attach a 16-gauge jumper wire (or thicker) across the two terminals on the remote start terminal block. (This applies a ground to the controller to close the starting circuit contacts.) The engine cranks, then starts, then runs.
4. Remove the jumper wire from the remote start terminal block. The engine stops. Reconnect any necessary wires from the remote start switch (transfer switch) to the remote start terminal block.
5. Verify the unit is in AUTO mode. See [Switching Controller Mode](#) if necessary.
6. Close and lock all access doors.

The unit is ready for remote starting.

## Remote Start Terminal Block

The remote start terminal block provides a connection to install a remote start switch, which allows unit startup through a remote dry-contact closure switch.

**IMPORTANT NOTE:** Before starting in AUTO mode, verify the contacts of any remote switch linked to the unit are open. If the contacts of a remote switch are closed, the engine will crank and start, when AUTO mode is started. Attach the switch leads to the two unused terminals (A) on the remote start terminal block.

See [Figure 3-6](#). The remote start terminal block is inside the control box, on the rear panel. Access the remote start terminal block by opening the control panel box.

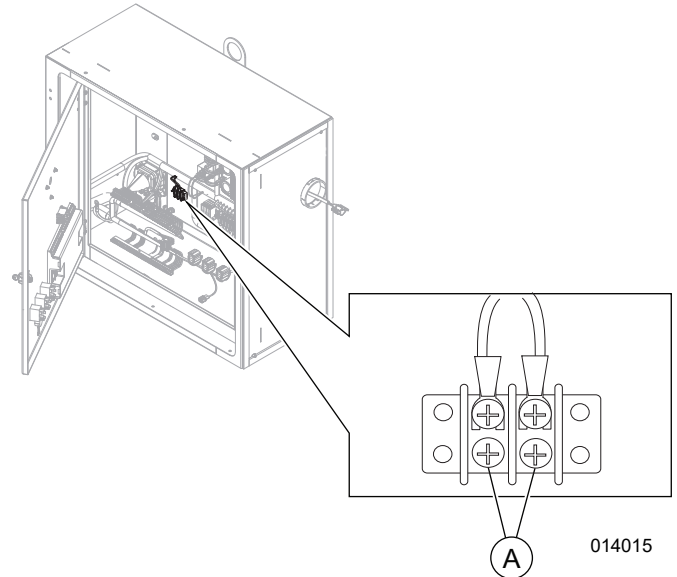

**Figure 3-6. Remote Start Terminal Block**

## Parallel Setup and Operation (If Equipped)

This system is designed to work with generators that are connected on the mobile switching center (MSC) network only and not with the utility or any other independent power source. All other power sources must be isolated from the MSC network to prevent potential damage due to power sources closing out of phase.

See [Figure 3-7](#) and [Figure 3-8](#). One unit serves as the primary unit. The primary unit controls up to 31 secondary units.



**Figure 3-7. Two Units in Parallel**

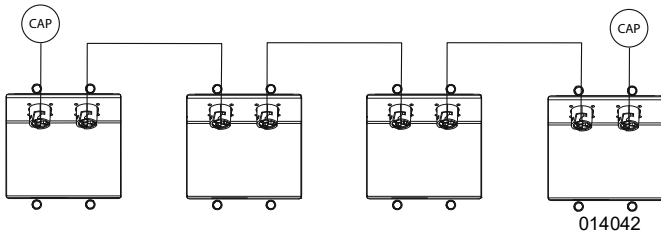

**Figure 3-8. Three or More Units in Parallel**

Secondary units synchronize with the primary unit.

### Manual Paralleling

1. Verify the units to be paralleled are OFF.
2. Secure all electrical connections to each unit and a common bus. Before connecting, ensure all wiring is properly color coded or labeled.

**IMPORTANT NOTE: Any crossed connection will prevent paralleling function.**

3. Connect MSC cable(s) and terminating plugs (resistors) to the end units.
4. Switch the battery disconnect to ON.
5. Set controller mode to MANUAL. See [Switching Controller Mode](#).
6. Start each unit intended for paralleling. Allow all to warm up.
7. Press the Close Circuit Breaker button on each unit.

### Automatic Paralleling

1. Verify the units to be paralleled are OFF.
2. Secure all electrical connections to each unit and a common bus. Before connecting, ensure all wiring is properly color coded or labeled.

**IMPORTANT NOTE: Any crossed connection will prevent paralleling function.**

3. Connect MSC cable(s) and terminating plugs (resistors) to the end units.
4. Switch the battery disconnect to ON.
5. Connect two wire start signal (dry contact closure) to all the generators on the MSC network. The contact closure will be in parallel.
6. Set controller mode to AUTO. See [Switching Controller Mode](#).

### Switching Controller Mode

**NOTE:** When switching controller mode, the engine can be running, but it is not required.

**NOTE:** See [General Information](#) for explanation of each mode.

1. Switch controller ON.
2. Stop drawing power from the unit: Stop using equipment plugged into receptacles, cam locks, and anything connected to the lugs.
3. See [Figure 3-9](#). Press the desired Mode button. The controller mode immediately changes, and the corresponding LED illuminates.

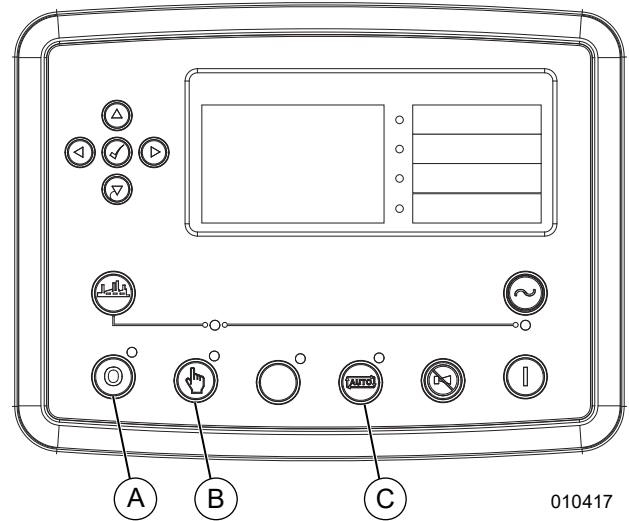

**Figure 3-9. Mode Buttons**

- A STOP Mode button
- B MANUAL Mode button
- C AUTO Mode button

### Fine Tuning the Voltage

Voltage adjustment range is  $\pm 10\%$ . This can be done when engine is running and breaker is closed to fine tune voltage output at load connection.

**IMPORTANT NOTE: This procedure is only permitted on non-parallel capable machines. Machines set up with parallel controls will not respond to voltage adjustments when the breaker is closed.**

See [Figure 3-10](#). Use the controller navigation buttons to fine-tune generator output voltage.

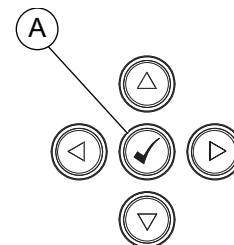

**Figure 3-10. Navigation Buttons**

4. From the Home page, press and hold the CHECK-MARK button (A) to access the Running configuration editor - display.



5. Press the UP or DOWN button to scroll to the Editor - Generator Voltage Adjust L-N page.
6. Press and release the CHECKMARK button so the voltage starts to flash.
7. Press the UP or DOWN button to change voltage.
8. Press and release the CHECKMARK button to set and save the voltage setting. The value stops flashing.

**NOTE:**

- The new voltage setting is retained through ON-OFF cycles of the generator.
  - When battery power is cycled through the battery disconnect switch, the voltage setting returns to the target voltage for which the link board is configured.
9. Press and hold the CHECKMARK button to exit the Running configuration editor.

## Voltage Regulator

The voltage regulator controls the output of the generator by regulating current into the exciter field. The voltage regulator is adjusted before shipment from the factory and typically does not require adjustment.

## Main Circuit Breaker

See [Figure 3-11](#). The main circuit breaker is on the unit backside, between the control panel and AC distribution panel.

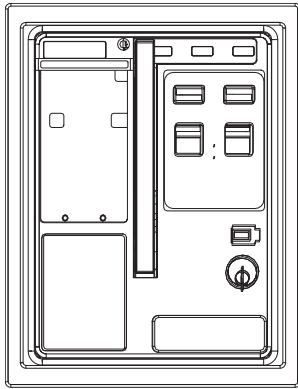

**Figure 3-11. Main Circuit Breaker**

When the main line circuit breaker (MLCB) is OFF (O), power is interrupted to the connection lugs and the optional cam lock receptacles. The breaker may be switched ON (I) after connections have been made to the connection lugs or the optional cam lock receptacles, and the unit has been started and allowed to reach normal operating speed and temperature.

The convenience receptacles have separate circuit breakers protecting those circuits and operate independent from the MLCB. If the MLCB is switched off, the convenience receptacles may still provide power.

Verify the 20/50 A circuit breakers for their respective circuits.

Any of the following conditions can trip the main circuit breaker:

- Overload of the generator circuits to the connection lugs or the optional cam lock receptacles.
- The door covering the connection lugs is open.
- The door covering the cam lock receptacles (if equipped) is open.
- The link board cover panel is removed.
- The Emergency Stop switch is active.

Before switching the breaker ON (I), verify ALL problems causing breaker-trip are resolved.

**NOTE:** The MLCB controls power ONLY to the connection lugs and cam lock receptacles (if equipped). It does NOT control power to the convenience receptacles. When the main circuit breaker is OFF (O), convenience receptacles remain powered. Each convenience receptacle is controlled by an individual circuit breaker, located near the receptacle. Verify the 20/50 A fuses for the respective circuits.

## Motorized Breaker (If Equipped)

Units with paralleling function are equipped with a motorized main circuit breaker. The motorized breaker can be closed electronically, through the controller.

## Connection Lugs

**⚠ DANGER**

Electrical backfeed. Use only approved switchgear to isolate generator from the normal power source. Failure to do so will result in death, serious injury, and equipment damage.

(000237)



**⚠ DANGER**

Electrocution. Do not disable or modify the connection box door safety switch. Doing so will result in death or serious injury.

(000157)



**⚠ DANGER**

Electrocution. Before connections are made to the unit, verify the main circuit breaker and battery disconnect switch are OFF. Failure to do so will result in death or serious injury.

(000156)

**⚠ WARNING**

Electric shock. Only a trained and licensed electrician should perform wiring and connections to unit. Failure to follow proper installation requirements could result in death, serious injury, and equipment or property damage. (000155a)

The installation should be in compliance with the national electrical code (NEC), state, and local regulations.

See **Figure 3-12**. Generator connection lugs are on the unit backside, behind the lug box door. The lugs provide connection points to attach external loads to the generator.

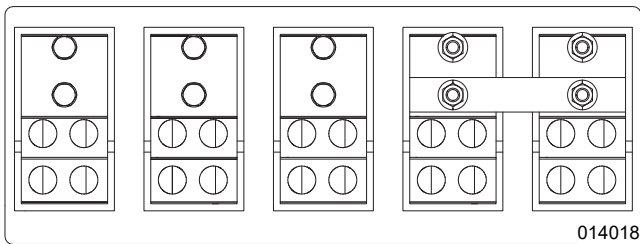

**Figure 3-12. Connection Lugs**

Decals above the connection lugs identify the lugs.

Decal
L1
L2
L3
N (Neutral)
G (Ground)

**Connecting to Lugs**

Connect to the lugs by routing power cables through the opening in the bottom of the door. The tightening torque for the set screws on the connection lug is 30 ft-lb (41 Nm).

**IMPORTANT NOTE: Do not make any connections directly to the lugs without routing the cables through the opening. Use a hex-wrench to tighten the cable connections.**

**IMPORTANT NOTE: There is permanent conductor between the generator (stator winding) and the frame.**

The connection lug door is equipped with safety interlock switches. If the door is opened when the unit is operating, the interlock switches trip the main circuit breaker, disable the voltage regulator, and shut down the unit.

See **Figure 3-13**. A ground connection (A) is located on

the curbside rear exterior of the generator. The unit must be connected to ground for proper operating safety. The generator neutral is bonded to ground when it is shipped from the factory. The bonding plate must be removed when the generator is used as a standby power source. Installation should be in compliance with the National Electrical Code (NEC), state, and local regulations.

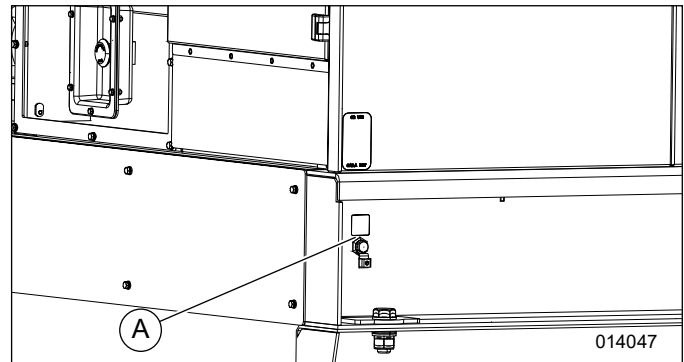

**Figure 3-13. Grounding Lug**

**Cam Lock Connections (If Equipped)**



**⚠ DANGER**

Electrocution. Before connections are made to the unit, verify the main circuit breaker and battery disconnect switch are OFF. Failure to do so will result in death or serious injury. (000156)

**⚠ DANGER**

Electrical backfeed. Use only approved switchgear to isolate generator from the normal power source. Failure to do so will result in death, serious injury, and equipment damage. (000237)



**⚠ WARNING**

Electric Shock. Verify all connections to the cam lock receptacles are made to one side only. Failure to do so could result in death, serious injury and property damage. (000308)

**⚠ WARNING**

Electric shock. Only a trained and licensed electrician should perform wiring and connections to unit. Failure to follow proper installation requirements could result in death, serious injury, and equipment or property damage. (000155a)

See **Figure 3-14**. The unit may be equipped with cam lock connections. If equipped, they are on the unit backside, below the connection lugs.

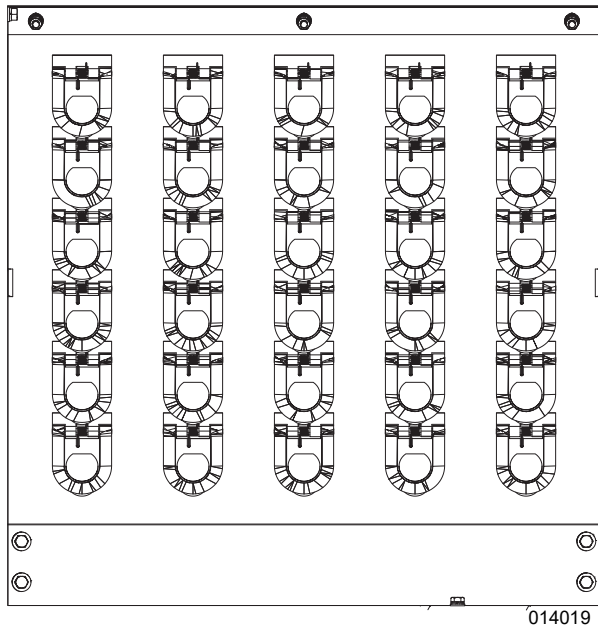

**Figure 3-14. Cam Lock Panel**

Cam locks provide connection points to attach external loads to the generator.

Above the connection lugs, decals describe the cam locks. Also, cam locks are color-coded, according to country of destination.

Decal	Color—USA	Color—Canada
L1	Black	Red
L2	Red	Black
L3	Blue	Blue
N (Neutral)	White	White
G (Ground)	Green	Green

**IMPORTANT NOTE:** The nation for which the unit is configured determines cam lock colors, and decals indicate which color convention is being followed.

Connections should be made by plugging power cables equipped with series 16 taper nose 400 A, 600 V cam lock plugs into the cam lock receptacles. Secure connection by rotating plug one-half turn to the right.



**⚠ DANGER**

Electrocution. Do not disable or modify the connection box door safety switch. Doing so will result in death or serious injury.

(000157)

## Convenience Receptacles

**⚠ CAUTION**

Equipment Damage. Verify voltage application before making changes to factory settings. Incorrect voltage applied to a load could result in equipment damage. (000303)

See **Figure 3-15**. The unit is equipped with various receptacles.

- The 240/120 VAC twist-lock receptacles are rated at 50 A each.
- The 120VAC duplex receptacles are rated at 20 A each, with ground fault circuit interrupt (GFCI) protection.
- Convenience receptacles are NOT routed through the main line circuit breaker. Each receptacle has its own circuit breaker, located directly above or next to the receptacle. Each breaker is sized to the maximum rating of the corresponding receptacle.

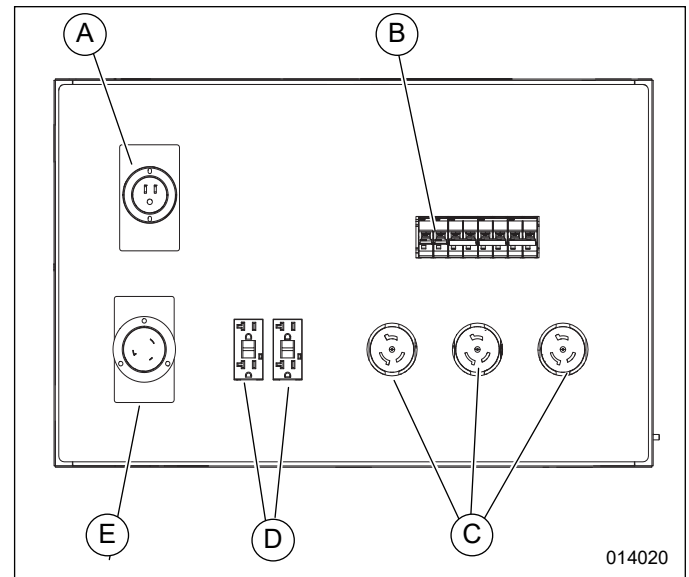

**Figure 3-15. Receptacles, Breakers—Covers Removed**

<b>A</b>	125 V, 15 A battery charger shore power plug (5-15P) (If equipped)
<b>B</b>	Receptacle circuit breaker panel
<b>C</b>	240 V, 50 A, 3 Pole, twist-lock receptacles (CS6369)
<b>D</b>	120 V, 20 A, GFCI, duplex receptacle (NEMA 5-20R)
<b>E</b>	125 V, 30 A winter heater shore power plug (L5-30P) (If equipped)

**IMPORTANT NOTE:** All receptacles are powered when the generator is running, even when the main circuit breaker is OFF (O).

## Correct Receptacle Use

Before switching breakers to ON (O) positions, ensure equipment connected to receptacles is switched OFF. This machine is equipped with a buck transformer which will step down the voltage at the receptacles to ensure proper voltage output in each of the link board positions.

**NOTE:** Generac Mobile does not recommend using the receptacles in the 600 V position.

- When the link board is set to 480/277 VAC, 3-phase, each GFCI receptacle delivers 120 VAC and each twist lock receptacle delivers 240/139 V.
- When the link board is set to 240/120 VAC, 3-phase, each GFCI receptacle delivers 120 VAC and each twist lock receptacle delivers 240/139 V.
- When the link board set to 208/120 VAC, 3-phase, each GFCI receptacle delivers 120 VAC and each twist lock receptacle delivers 208/120 V.
- When the link board set to 600/346 VAC, 3-phase, the buck transformer is not capable of stepping down voltage to an acceptable range. Generac Mobile does not recommend using the receptacles in the 600 V position.

## Transfer Switch

### **⚠ DANGER**

Loss of life. Property damage. Installation must always comply with applicable codes, standards, laws and regulations. Failure to do so will result in death or serious injury. (000190)

### **⚠ DANGER**

Electrical backfeed. Use only approved switchgear to isolate generator from the normal power source. Failure to do so will result in death, serious injury, and equipment damage. (000237)

### **⚠ WARNING**

Electric shock. Only a trained and licensed electrician should perform wiring and connections to unit. Failure to follow proper installation requirements could result in death, serious injury, and equipment or property damage. (000155a)



### **⚠ WARNING**

Electric shock. Phase rotation must be compatible. Incompatible phase rotation could result in death, serious injury, or equipment damage. (000226b)

The installation should be in compliance with the National Electrical Code (NEC), and state and local regulations.

**IMPORTANT NOTE: This must be performed by a certified electrician.**

Before attempting any connections, verify the main circuit breaker and the control power switch are in the OFF (O) position and that the negative (-) battery cable has been disconnected from the battery.

Installation of such devices must be performed by following all directions supplied by the manufacturer of the switch. If attaching the unit to a power supply normally serviced by a utility company, notify the utility company and check state and local regulations. Familiarize yourself with all instructions and warning labels supplied with the switch.

When the unit is used as a standby power supply, it must be equipped with a transfer switch that isolates it from the utility's distribution system. A transfer switch is designed to transfer electrical loads from the normal power source (utility) to the emergency power source (generator) when normal voltage falls below a prescribed level. The transfer switch automatically returns the load back to the normal source when power is restored back to operating levels.

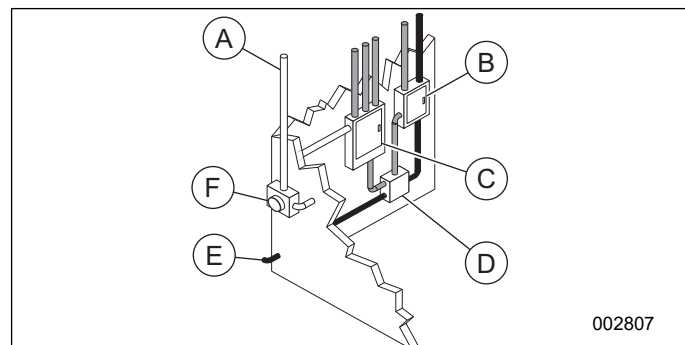

**Figure 3-16. Transfer Switch Operation**

<b>A</b>	Incoming utility power
<b>B</b>	Emergency distribution panel (generator power)
<b>C</b>	Main distribution panel (utility power)
<b>D</b>	Transfer switch
<b>E</b>	Power from generator
<b>F</b>	Utility meter
<b>WHITE</b>	Incoming utility power
<b>GRAY</b>	Normal utility power circuit
<b>BLACK</b>	Emergency generator power circuit

## Changing Exercise Timers

If exercise timers or scheduled runs are needed, contact a GMASD for assistance.

## PAS, Installation, Operation & Testing (if equipped)

See **Figure 3-17**. The PAS is installed on the intake pipe in between the charged air cooler and the engine intake manifold. The valve body has an internal butterfly valve to close off air flow. There is also a visual indicator on the external part of the valve body to know if the valve is closed or open.

See **Figure 3-18**. To perform a functional test of the Positive Air Shutoff (PAS), the engine must be off, and the battery disconnect switch (BDS) ON to provide power to the controller and generator accessories. The E-Stop must also be activated (pressed) to prevent engine start up during the test cycle. To activate the test cycle, the TEST button on the control panel must be pressed and held for 5 seconds. The LED adjacent to the TEST button will illuminate when the test cycle is active. The following message “POSITIVE AIR SHUTDOWN” will be displayed

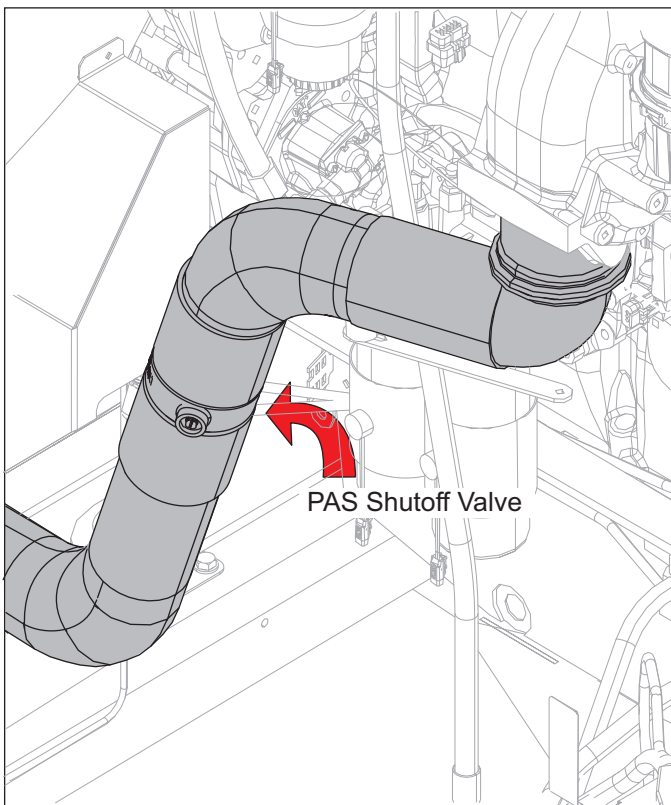
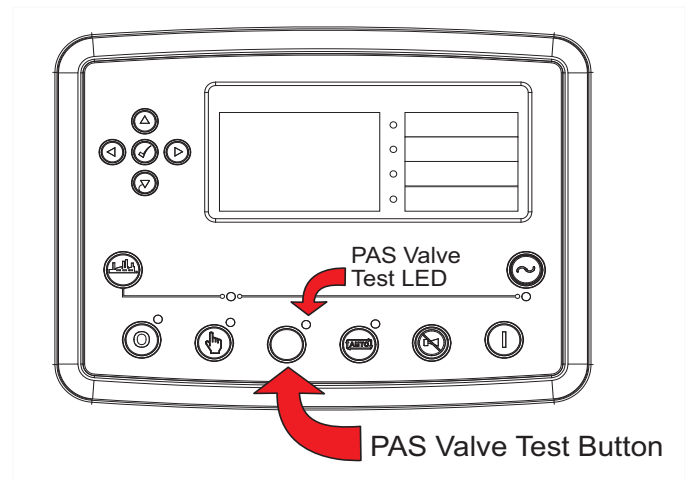

**Figure 3-17. PAS Location**

on the control panel screen when the test cycle is active. The PAS will cycle once and close for 15 seconds. During this period, the engine will be locked out and cannot be started. The E-Stop must also be manually deactivated. To visually observe the closure of the valve, the shaft of the valve can be observed rotating 90°. The slotted cutaway is the visual indicator, located on the body of the valve as seen in the image. If the slot is parallel to the direction of air flow the valve is open. If it is

perpendicular, the valve is closed.

During normal operation, the PAS can be activated automatically without operator intervention if certain variables are satisfied that would indicate an engine over speed condition has occurred. If the engine speed or generator frequency exceeds 2200 RPM (73 Hz), the PAS will close immediately to prevent further speed elevation and potential permanent damage to the engine and/or alternator. In this condition, the PAS will cycle



**Figure 3-18. PAS Test Button**

closed and remain closed for 15 seconds cutting off air flow to the engine and bringing it to a stop. A warning will be displayed on the screen and an event will be logged into the controller history.

**NOTE:** The PAS cannot and should not be used to stop engine during normal operation. This can and will cause permanent engine damage.

### Shutting Down the Unit

Before shutting down the unit, check with personnel using power supplied by the generator and let them know the power is being switched off. Verify the power shutdown will not create any hazards by accidentally turning off equipment that must continue operating (such as pumps, compressors, lights).

1. Remove all loads from the generator by opening all circuit breakers (turn to the OFF (O) position).
2. Allow engine to run for approximately five minutes to allow it to cool down.
3. Press the red engine STOP/RESET (O) button on the controller.
4. After pressing the red engine STOP/RESET (O) button, the unit may continue to run for an additional cool down period. This is being driven by the



engine controller to ensure engine temperatures have cooled sufficiently.

5. After the unit shuts down, wait for the battery disconnect LED to turn off. When the LED shuts off. Then, it is safe to switch the disconnect connect switch to off.

**NOTE:** The ECU must run for 90 seconds after shutdown to purge the DEF.

**NOTE:** Switching off the control panel before the controller finishes updating could cause a loss of data.

**NOTE:** For extended storage time, disconnect the battery. See the OEM engine manual for extended storage requirements.

**NOTE:** If any units are in parallel, do not disconnect the MSC cable.

## Emergency Stop Switch



Equipment Damage. The emergency stop switch is not to be used to power down the unit under normal operating circumstances. Doing so could result in equipment damage. (000246b)

See [Figure 3-19](#). The unit is equipped with one emergency stop switch. The red button is clearly labeled EMERGENCY STOP. The switch can be accessed and activated with all doors closed and locked.

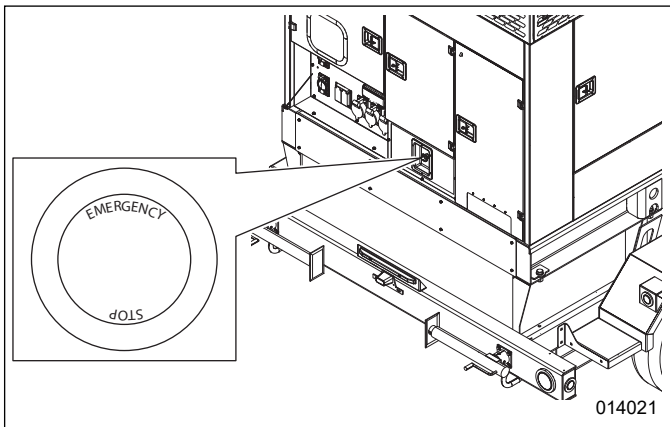

**Figure 3-19. Emergency Stop Switch**

Using the emergency stop switch overrides normal shutdown sequence and bypasses the engine cool-down period.

**IMPORTANT NOTE:** Using the emergency stop switch for regular shutdown can result in equipment damage.

Activate the emergency stop switch by pushing the button in until it locks down. This trips the main circuit breaker which then opens the contact, disconnecting the load to the connection and ultimately shuts down the

engine. The emergency stop fault will be displayed on the control panel. The switch will remain closed until it is pulled out. The emergency stop should only be used in emergency situations and not be used to shutdown the generator during normal operation. Using the emergency stop switch overrides normal shutdown sequence.

## Towing the Unit

**NOTE:** Before towing the unit, see [Trailer Hazards](#) and [Towing Safety](#).

## Hitch and Coupling Guidelines

- Verify the hitch and coupling on the towing vehicle are rated equal to, or greater than, the trailer's Gross Vehicle Weight Rating (GVWR).
- Verify the trailer hitch and the coupling are compatible. Verify the coupling is securely fastened to the vehicle.
- **DO NOT** tow trailer using defective parts. Inspect the hitch and coupling for wear or damage.
- Connect safety chains in a crossing pattern under the tongue.
- Before towing the trailer, verify the weight of the trailer is equal across all tires. On trailers with adjustable height hitches, adjust the angle of the trailer tongue to keep the trailer as level as possible.

## Preparing Unit for Towing

1. Verify engine is OFF.
2. Use the tongue jack to raise or lower the trailer onto the hitch of the towing vehicle. Lock the hitch coupling and attach the safety chains or cables to the vehicle. Raise the tongue jack to the highest positions providing the maximum clearance between the ground and the jack.

**NOTE:** Maintain a film of grease on the coupler to extend coupler life and eliminate squeaking. Before towing, wipe the coupler clean and apply fresh grease.

3. Lubricate grease fittings on leveling jacks to ensure proper operation of the jacks. See [Jack Maintenance](#). For maintenance interval information, see [Basic Maintenance Schedule](#).
4. Connect trailer wiring harness to tow vehicle. Verify proper operation of directional and brake lights.
5. Verify all doors and hoods are properly latched.
6. Verify all tires are inflated to the correct pressure. See [Specifications](#).
7. Check all wheel lugs. Tighten or replace any loose or missing lugs. If a tire was removed for axle ser-

vice or replaced, tighten lugs in the order shown in [Figure 3-20](#) to the following specifications:

- Start all lug nuts by hand.
- First pass tighten to 50–60 ft-lb (67–81 Nm).
- Second pass tighten to 150–200 ft-lb (203–271 Nm).
- Third pass tighten to 275–325 ft-lb (373–441 Nm).

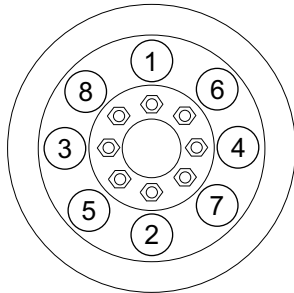

**Figure 3-20. Lug Sequence**

001441

**WARNING**

Property or Equipment Damage. Tighten wheel lug nuts after first 50 miles to factory specifications. Failure to do so could result in death, serious injury, property or equipment damage. (000235)

- Verify all axle oil baths have adequate levels for towing.

**Recommended Towing Speed**

- Maximum highway speed: 65 mph (104 km/h), or in accordance with local traffic laws and ordinances.
- Maximum off-road speed: 10 mph (16 km/h), depending on terrain.

**Lifting the Unit**

**Trailer and Skid-Mounted Units**

**NOTE:** Before lifting the unit, see [Lifting Hazards](#).

**NOTE:** Always be aware of people and objects around the work site when moving or lifting the unit.

- Verify the machine used to lift the unit is in good condition and has sufficient lifting capacity. See [Specifications](#) for approximate unit weights.
- Close and lock all hoods and doors.
- Choose lifting chains, slings, and hooks, according to unit dimensions. See [Unit Dimensions](#).
- See [Figure 3-21](#). For a single lift point, attach hook to lift eye (A). For multi-lift point, use spreader bars and lift chains that are appropriately rated for this machine. Attach chain to 4 point lift eyes (B). See unit dimensions.

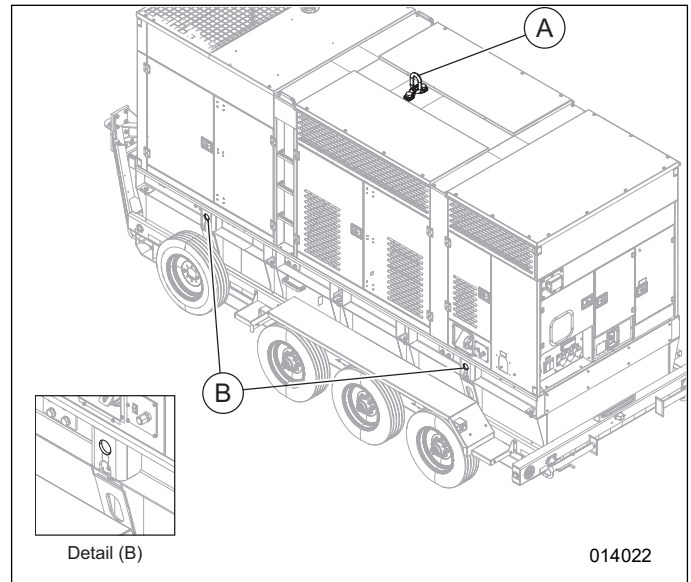

**Figure 3-21. Trailer-Mounted Unit**

014022

**NOTE:** See [Figure 3-22](#). Do NOT connect lifting equipment to indicated holes (A).

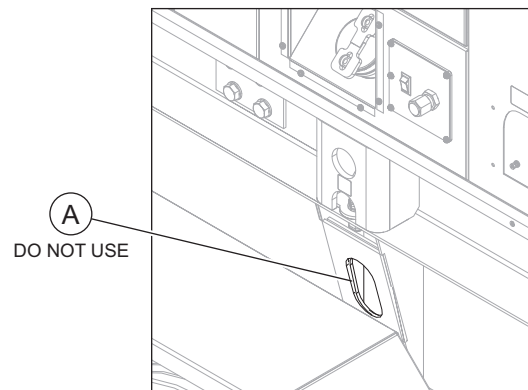

**Figure 3-22. NOT Lifting Points (Four Locations)**

014023

See [Figure 3-21](#) (item B) for the correct lifting points

**Skid-Mounted Units ONLY**

Skid mounted units can be lifted multiple ways:

- See [Figure 3-23](#). Skid mounted units can also be lifted using the fork pockets (B).
- Before lifting, verify all obstructions are clear of forks, pockets, and other parts of the unit.
- Approach unit squarely, as illustrated.

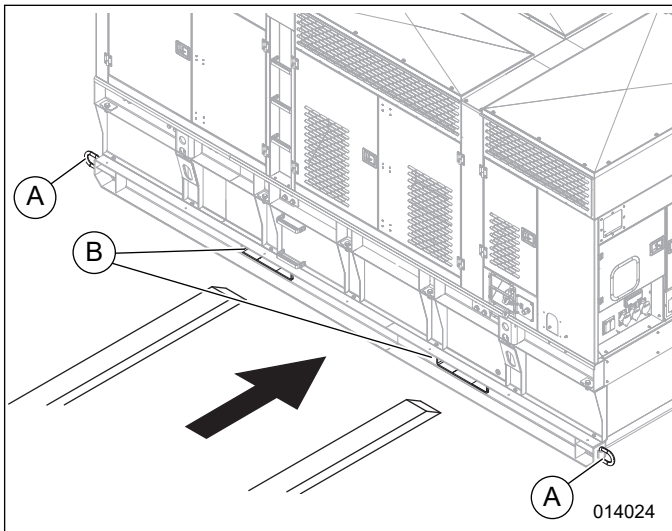

**Figure 3-23. Skid-Mounted Unit**

**NOTE:** The forklift must be capable of a 60.1 in (1.35 m) blade spread, or greater.

**NOTE:** The forklift must have sufficient lifting capacity. See [Specifications](#) for approximate unit weights.

**NOTE:** Use forklift pockets with care. Failure to approach the unit squarely can result in permanent damage to the unit.

## Dragging the Unit (Skid Mounted Units Only)

**IMPORTANT NOTE:** This procedure **ONLY** applies to skid-mounted units. Do **NOT** attempt this procedure on trailer-mounted units.

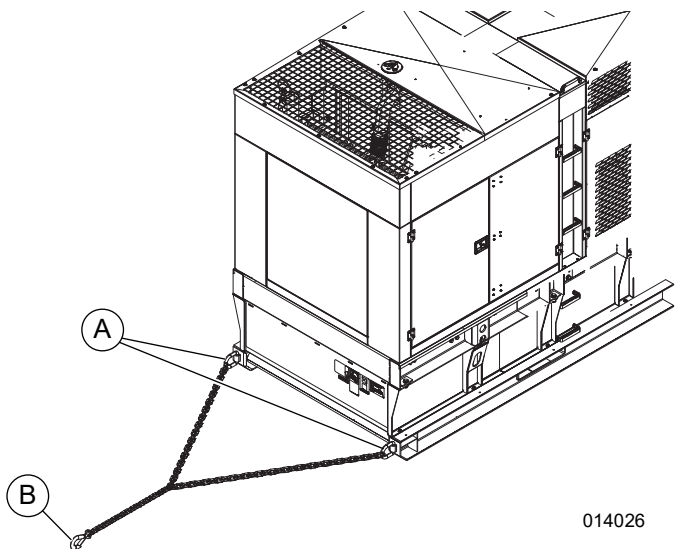

**Figure 3-24. Dragging the Unit**

1. See [Figure 3-24](#). Attach a suitable chain to each D-Ring (A). D-Rings are located on the front and rear of the machine.
2. Attach the chains to a suitable tow vehicle (B).

**NOTE:** The D-Rings are not to be used for lift the entire generator. D-Rings are designed for dragging generator on skid frame.

## Tying Down the Unit

When securing the unit for transportation, verify the equipment being used to fasten the unit is in good condition and has sufficient strength to hold the unit in place during transport.

See [Figure 3-25](#). Use the tie-down points (A) as shown.

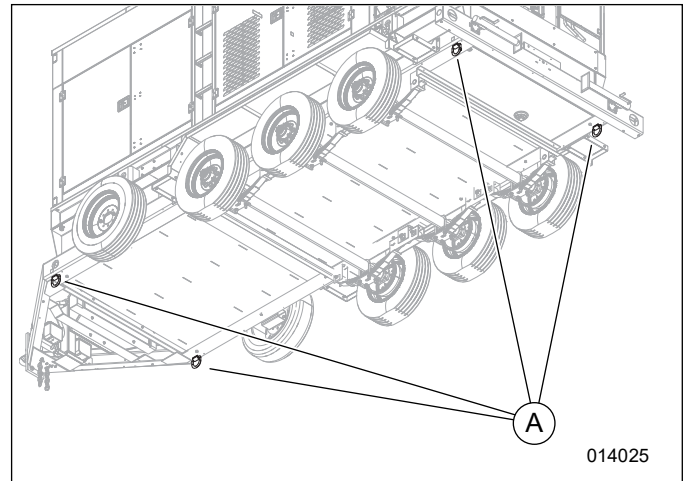

**Figure 3-25. Tie-Down Points**



# Section 4: Maintenance

---

## Emissions Information

For emissions information, see the OEM diesel engine manual.

## Maintenance

Regular maintenance ensures correct machine performance and extends engine/equipment life. Generac Mobile recommends that all maintenance work be performed by a GMASD. Regular maintenance, replacement, or repair of the emissions control devices and systems may be performed by any repair shop or person of the owner's choosing. To obtain emissions control warranty service free of charge, the work must be performed by a GMASD. See the emissions warranty.

## Daily Walk Around Inspection



Equipment Damage. Failure to perform a daily inspection could result in damage to the unit.

(000306)

- Inspect for conditions that could hinder performance or safety, such as (but not limited to) proper oil, coolant, DEF and fuel levels, blocked vents, loose or missing hardware, and improper electrical connections. When engine is stopped and completely cool, coolant may be added directly to the radiator.
- Oil may also be added directly to the fill tube. See the OEM engine manual for the proper viscosity grade of oil, including special operating conditions such as a change in season or climate. DO NOT start the unit if the engine oil level is below the add mark on the dipstick. Normal operating level is in the cross-hatch pattern between the FULL and ADD markings on the dipstick. Add oil only if the oil level is below the ADD mark on the bottom of the cross-hatch pattern on the dipstick. DO NOT OVERFILL the crankcase.
- Inspect the fan belt for signs of cracking, fraying, and stretching, and verify the belt is properly seated in the pulley grooves. Replace the belt according to the manufacturer's recommendations.
- Inspect containment basin and properly dispose of any fluid in containment basin.
- Verify the condition of the air filter by viewing the level of the vacuum draw on the filter minder gauge. Replace the air filter when the yellow center

bar reaches the red section on the gauge (20 in. H<sub>2</sub>O).

- Inspect condition of electrical cords. DO NOT use the unit if insulation is cut or worn through.
- Check tire pressure, lug nut torque, and axle oil bath levels according to manufacturers recommendations. If unit is going to be stationary for extended period daily checks of the wheels and axles are not required. If unit has been stationary for an extended period and will be transported, a thorough inspection is necessary to ensure wheels and axles are in proper working order. Inspect the wheel bearings for unusual wear. See [Trailer Wheel Bearings](#).

**NOTE:** If the engine was run out of fuel, or the fuel tank was drained, it may be necessary to purge the fuel lines.

See the OEM engine manual supplied with the unit for more information.

## General Maintenance

Poorly maintained equipment can become a safety hazard. Periodic maintenance and occasional repairs are necessary in order for the equipment to operate safely and properly over a long period of time. Never perform any routine service (such as oil and oil filter changes, cleaning) unless all electrical components are shut off. Before servicing the unit, always follow the instructions listed below.

- Verify the controller power switch is OFF (O).
- Verify the battery disconnect switch is OFF (O).
- Verify the circuit breakers are OFF (O).
- Activate (push in) the E-Stop switch.
- Disconnect battery negative (-) cable.
- Attach a DO NOT USE sign to the control panel. This signifies that the unit is being serviced and reduces the chance of someone inadvertently trying to start the unit.
- If the unit is connected to a remote start or transfer switch, verify the remote switch is OFF and tagged with a DO NOT USE sign.
- ONLY power wash the unit exterior. Do NOT power wash any part of the unit interior.
- Do not wash the engine block or fuel tank with a power washer or steam cleaner. Water may enter the cabinet and collect in the generator windings or other electrical parts, causing damage.
- Inspect coolant system for leaks.

- Inspect coolant level. Coolant should be visible in the sight-glass, located on the top tank of the radiator. Fill as needed.

## Fuel Recommendations

**IMPORTANT NOTE: DO NOT use home heating oil or bio-diesel fuel.**

**IMPORTANT NOTE: Comply with all laws regulating the storage and handling of fuels.**

This unit is designed to operate with diesel fuel. Follow these guidelines:

- Use only ultra-low-sulfur (15 ppm) diesel fuel.
- When temperatures are at or below freezing, use No. 1 diesel fuel.
- When temperatures are above freezing, use No. 2 diesel fuel.
- In some areas of the country, climatized fuel—a mixture of 1D and 2D, may also be used.

For more information, see the OEM engine manual (Generac publication PN A0001715045), *Maintenance* section.

## Adding Fuel



**⚠ DANGER**

Explosion and Fire. Fuel and vapors are extremely flammable and explosive. Keep fire and spark away. Failure to do so will result in death or serious injury. (000168)



**⚠ DANGER**

Explosion and Fire. Do not overfill fuel tank. Overfilling may cause fuel to leak and ignite or explode, resulting in death or serious injury. (000204)

**NOTE:** Never allow dust, foreign matter, or water to enter fuel tank.

**NOTE:** See [Specifications](#) for fuel tank capacity.

1. Place unit on a firm, level surface in a well ventilated area.
2. Verify unit is OFF.
3. Remove fuel fill cap.
4. Fill tank with diesel fuel to 0.25 in (6.4 mm) from the bottom of fill neck to allow for fuel expansion. See [Resetting Maintenance Alarms](#). Install fuel fill cap.

**NOTE:** Properly contain, clean, and dispose of spilled fuel.

The fuel tank can be filled via the externally mounted fill

neck located on the rear corner roadside panel of the machine. The fuel tank level can be monitored on the control panel display or the analog gauge located on top of the fuel tank near the battery tray on roadside of the machine. The fill neck can accept nozzles up to 1.5" (38mm) but flow rate should be limited to less than 65 GPM (246 LPM) to prevent blow back of fuel. When filling the tank, never top off the tank such that the fill neck is filled with diesel fuel. This will prevent fuel spills and allow proper tank ventilation.

The standard fuel tank does not come equipped with fuel containment or fuel tank drain. If fuel ever needs to be drained from tank, it should be pumped out of the tank and into a proper container.

The optional fuel tank does come equipped with fuel containment and a rupture basin alarm. This alarm will display a warning message on the controller display. The fuel can be drained from the containment basin using the drain plug located on the bottom of the tank.

## Engine Oil Recommendations

To maintain the product warranty, the engine oil should be serviced in accordance with the recommendations of this manual. The engine has been filled with factory engine oil of a grade recommended by the engine supplier.

Use a high quality detergent oil with an appropriate classification and viscosity for the engine type and ambient temperature conditions. Contact a GMASD or refer to the applicable engine service manual for more information.

### Commercial Oils

Perkins recommends use of Perkins Diesel Engine Oil for all Perkins engines. Perkins unique oil formulations have been developed to provide full performance and maximum service life of your engine, and in tests have been shown to provide superior protection. Available in suitable API classifications to meet the emissions requirements and performance of your engine, see [Table 4-3](#) for the correct oil specification for your engine. Consult your Perkins distributor for more information on these multi-grade oils.

**IMPORTANT NOTE: Perkins requires the use of the following specification of engine oil. Failure to use the appropriate specification of engine oil will reduce the life of your engine. Failure to use the appropriate specification of engine oil will also reduce the life of your aftertreatment system.**

**Table 4-3. Oil Specifications**

API CK-4
ACEA E9
ECF-3

API CK-4 and ACEA E9 oil categories have the following chemical limits:

- 0.1% maximum sulfated ash
- 0.12% maximum phosphorous
- 0.4% maximum sulfur

The chemical limits were developed to maintain the expected life of the engine aftertreatment system. The performance of the engine aftertreatment system can be adversely affected if oil that is not specified in [Table 4-3](#) is used.

The life of your aftertreatment system is defined by the accumulation of ash on the surface of the filter. Ash is the inert part of the particulate matter. The system is designed to collect this particulate matter. There is a small percentage of particulate matter that is left behind as the soot is burnt. This matter will eventually block the filter, causing loss of performance and increased fuel consumption. Most of the ash comes from the engine oil which is gradually consumed during normal operation. This ash passes through the exhaust. To meet the designed life of the product, the use of the appropriate engine oil is essential. The oil specification that is listed in [Table 4-3](#) has low ash content.

**Maintenance intervals for engines that use biodiesel:**  
The oil change interval can be adversely affected by the

use of bio diesel. Use oil analysis to monitor the condition of the engine oil. Use oil analysis also to determine the oil change interval that is optimum.

**IMPORTANT NOTE: DO NOT use API FA-4 oil in Perkins engines. API FA-4 oil is designed for use in selected on-highway applications and is NOT designed to support off-road applications, including Perkins engines.**

**IMPORTANT NOTE: The following engine oils are NOT approved by Perkins and must not be used: CC, CD, CD-2, CF-4, CG-4, CH-4, and CI-4.**

### Lubricant Viscosity Recommendations for Direct Injection (DI) Diesel Engines

The correct SAE viscosity grade of oil is determined by the minimum ambient temperature during cold engine start-up, and the maximum ambient temperature during engine operation.

See [Figure 4-1](#) (minimum temperature) to determine the required oil viscosity for starting a cold engine.

See [Figure 4-1](#) (maximum temperature) to select the oil viscosity for engine operation at the highest ambient temperature that is anticipated.

Generally, use the highest oil viscosity that is available to meet the requirement for the temperature at start-up.

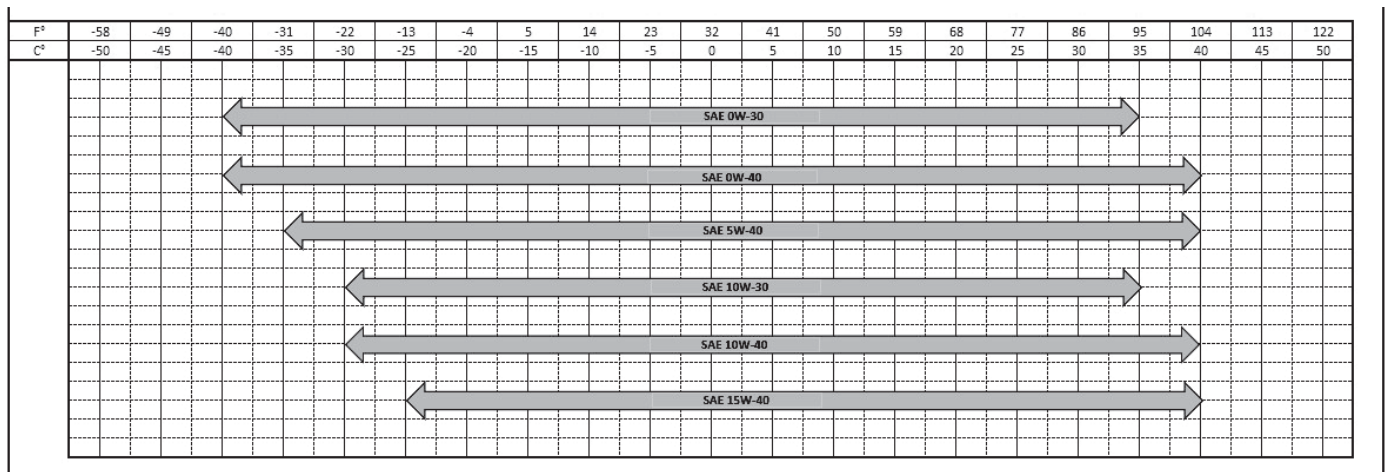

014866

**Figure 4-1. Lubricant Viscosities**

**NOTE:** Supplemental heat is recommended for cold soaked starts below 32 °F (0 °C). Cold soaked starts occur when the engine has not been operated for a period of time. This interval allows the oil to become more viscous due to cooler ambient temperatures.

### Aftermarket Oil Additives

Perkins does not recommend the use of aftermarket additives in oil. Aftermarket additives are not necessary to achieve the engines maximum service life or rated performance. Fully formulated, finished oils consist of base oils and of commercial additive packages. These

additive packages are blended into the base oils at precise percentages to help provide finished oils with performance characteristics that meet industry standards.

There are no industry standard tests that evaluate the performance or the compatibility of aftermarket additives in finished oil. Aftermarket additives may not be compatible with the finished oils additive package, which could lower the performance of the finished oil. The aftermarket additive could fail to mix with the finished oil. This failure could produce sludge in the crankcase. Perkins discourages the use of aftermarket additives in finished oils.

To achieve the best performance from a Perkins engine, conform to the following guidelines:

- See **Figure 4-1** to find the correct oil viscosity grade for your engine.
- At the specified interval, service the engine. Use new oil and install a new oil filter.
- Perform maintenance at the intervals that are specified in **Basic Maintenance Schedule**.

### Oil analysis

See **Figure 4-2**. This engine is equipped with an oil sampling valve (A).



**Figure 4-2. Oil Sampling Valve**

If oil analysis is required, the oil sampling valve is used to obtain samples of the engine oil. The oil analysis will complement the preventive maintenance program.

The oil analysis is a diagnostic tool that is used to determine oil performance and component wear rates. Contamination can be identified and measured by using oil analysis. The oil analysis includes the following tests:

- The Wear Rate Analysis monitors the wear of the engines metals. The amount of wear metal and type of wear metal that is in the oil is analyzed. The increase in the rate of engine wear metal in the oil is as important as the quantity of engine wear metal in the oil.
- Tests are conducted to detect contamination of the oil by water, glycol, or fuel.
- The Oil Condition Analysis determines the loss of the oils lubricating properties. An infrared analysis is used to compare the properties of new oil to the properties of the used oil sample. This analysis allows technicians to determine the amount of deterioration of the oil during use. This analysis also allows technicians to verify the performance of

the oil according to the specification during the entire oil change interval.

## Coolant Recommendation



**DANGER**

Risk of poisoning. Do not use mouth to siphon coolant. Doing so will result in death or serious injury.

(000149)



**WARNING**

Risk of burns. Do not open coolant system until engine has completely cooled. Doing so could result in serious injury.

(000154)

**CAUTION**

Risk of overheating. Do not use any chromate base rust inhibitor with propylene glycol base antifreeze, boosters, or additives. Doing so will cause overheating and possible equipment damage.

(000165a)

### Acceptable Coolant Types

Coolant Type	Service Life*
Perkins ELC	6,000 service hours or 3 years
Commercial heavy-duty anti-freeze that meets ASTM D6210	3,000 service hours or 2 years
Commercial SCA inhibitor and water	3,000 service hours or 1 year

\*Use the interval that occurs first. The cooling system must also be flushed at this time.

### Coolant Mixtures and Freezing Points

	Freezing Point °F (°C)			
	-12 (-24)	-34 (-36)	-54 (-48)	-90 (-67)
Water (% Volume)	50	40	40	40
Anti-freeze (% Volume)	50	60	60	60*

\* Maximum freeze protection is 60%.

**NOTE:** For more information, see OEM engine manual.



## DEF Recommendations



Equipment damage. Do not alter DEF. Use approved DEF only. Failure to do so could cause equipment damage.

(000337)

Diesel Exhaust Fluid (DEF) is a liquid that is injected into the aftertreatment system before Selective Catalytic Reduction (SCR). This system of injecting the DEF into the exhaust will cause a chemical reaction in the SCR system. The Nitrogen Oxide (NOx) molecules in the exhaust are converted to elemental nitrogen and water. This conversion will reduce the emission of the engine.

### Specification

DEF used in Perkins engines must meet the ISO specification 22241-1 for quality. The ISO specification 22241-1 requirements are met by many brands of DEF, including the ones that carry the AdBlue or API certification.

The document series ISO standard 22241 will give information on quality requirements, test methods, handling, transportation, storage, and refilling interface.

### Spillage

Care should be taken when dispensing DEF. Spills should be cleaned immediately. All surfaces should be wiped clean and rinsed with water.

DEF that has been spilled will crystallize when the water within the liquid evaporates. Spilled DEF will attack paint and metal. If DEF is spilled, wash the area with water.

Caution should be used when dispensing DEF near an engine that has recently been running. Spilling DEF onto hot components may cause the release of ammonia vapors. Do not breathe ammonia vapors. Do not clean up any spills with bleach.

### Filling the DEF Tank

The fill cap on the DEF tank must be colored blue. The DEF level is important, allowing the DEF tank to run dry or operate at a low level can affect the engine operation. Because of the corrosive nature of DEF, the correct materials must be used when filling a DEF tank. It is important to not top off the DEF tank. This will allow the tank vent to function properly and prevent any blockage to occur in the fill neck of the tank.

### DEF Quality

DEF quality can be measured with a refractometer. The DEF must comply with ISO standard 22241-1 with the urea solution of 32.5%.

### Cleanliness

Contaminants can degrade the quality and life of DEF. Filtering DEF is recommended when dispensed into the DEF tank. Filters should be compatible with DEF and should be used exclusively with DEF. Check with the filter supplier to confirm compatibility with DEF before using. Mesh-type filters using compatible metals, such as stainless steel, are recommended. Paper (cellulose) media and some synthetic filter media are not recommended because of degradation during use. Care should be taken when dispensing DEF. Spills should be cleaned immediately. Machine or engine surfaces should be wiped clean and rinsed with water. Caution should be used when dispensing DEF near an engine that has recently been running. Spilling DEF onto hot components will cause harmful vapors.

### Storage

**IMPORTANT NOTE: Do not store DEF in direct sunlight.**

**Table 4-4. Expected DEF Life @ Storage Temperature**

Storage Temperature—°F (°C)	Expected DEF Life
Below 77 (25)	18 months
77 to 86 (25 to 30)	12 months
86 to 95 (30 to 35)	6 months
Above 95 (35)	Test quality before use

Perkins recommend that all DEF taken from storage should be checked to ensure the DEF meets ISO standard 22241-1.

### Materials compatibility

DEF is corrosive. Due to the corrosion caused, DEF must be stored in tanks constructed of approved materials. Recommended storage materials:

Stainless steels:

- 304 (S30400)
- 304L (S30403)
- 316 (S31600)
- 316L (S31603)

Alloys and metals:

- Chromium Nickel (CrNi)
- Chromium Nickel Molybdenum (CrNiMo)
- Titanium

Non-metallic materials:

- Polyethylene
- Polypropylene
- Polyisobutylene
- Teflon (PFA)

- Polyfluoroethylene (PFE)
- Polyvinylidene fluoride (PVDF)
- Polytetrafluoroethylene (PTFE)

Materials NOT compatible with DEF solutions include Aluminum, Magnesium, Zinc, Nickel coatings, Silver and Carbon steel, and Solders containing any of the above. Unexpected reactions may occur if DEF solutions come in contact with any non-compatible material or unknown materials.

## Basic Maintenance Schedule

See the original equipment manufacturer's operating manual for a complete list of maintenance requirements. Failure to comply with the procedures as described in the OEM engine manual will nullify the warranty, decrease performance, and cause equipment damage or premature equipment failure. Maintenance records may be required to complete a warranty request.

**NOTE:** See the OEM engine manual for more maintenance information.

**Table 4-5. Basic Maintenance Schedule**

Item	Daily	Every 250 Hr	Initial 500 Hr	Every 500 Hr	Every 500 Hr/3 Mo	Every 500 Hr/1 Year	Every 2,000 Hr	Every 2,500 Hr	Every 3,000 Hr	Every 4,000 Hr	Every 5,000 Hr	Every 6,000 Hr	Every 10,000 Hr	Every 200,000 Gal (760,000 L) of fuel or 10,000 Hr	Every 12,000 Hr or 6 Yr	As Required
Air Tank Moisture and Sediment - Drain	◆															
Cooling System Coolant Level - Check	◆															
Driven Equipment - Check	◆															
Engine Air Cleaner Service Indicator - Inspect	◆															
Engine Oil Level - Check	◆															
Fuel System Primary Filter / Water Separator Drain	◆															
Walk-Around Inspection	◆															
Engine Oil Sample - Obtain		◆														
Grounding Stud - Inspect, Clean, and Tighten		◆														
Engine Valve Lash - check			◆													
Battery Electrolyte Level - Check				◆												
Cooling System Supplemental Coolant Additive (SCA) - Test/Add				◆												
Engine Oil and Filter - Change				◆												

**Table 4-5. Basic Maintenance Schedule**

Item	Daily	Every 250 Hr	Initial 500 Hr	Every 500 Hr	Every 500 Hr/3 Mo	Every 500 Hr/1 Year	Every 2,000 Hr	Every 2,500 Hr	Every 3,000 Hr	Every 4,000 Hr	Every 5,000 Hr	Every 6,000 Hr	Every 10,000 Hr	Every 200,000 Gal (760,000 L) of fuel or 10,000 Hr	Every 12,000 Hr or 6 Yr	As Required
Hoses and Clamps - Inspect/ Replace				◆												
Belts - Inspect/ Adjust/ Replace					◆											
Fuel system Primary Filter (Water Separator) Element - Replace						◆										
Fuel System Secondary Filter - Replace						◆										
Air Shutoff - Test							◆									
Electronic Unit Injector - Inspect/ Adjust								◆								
Engine Valve Lash - Check								◆								
Cooling System Coolant (DEAC) - Change									◆							
Air Compressor - Check										◆						
Engine Mounts - Inspect										◆						
Starting Motor - Inspect										◆						
ARD Spark Plug (Emission Related Component) - Clean											◆					
Diesel Exhaust Fluid Filter (Emission Related Component) - Replace											◆					
Diesel Particulate Filter (Emission Related Component) - Clean											◆					



**Table 4-5. Basic Maintenance Schedule**

Item	Daily	Every 250 Hr	Initial 500 Hr	Every 500 Hr	Every 500 Hr/3 Mo	Every 500 Hr/1 Year	Every 2,000 Hr	Every 2,500 Hr	Every 3,000 Hr	Every 4,000 Hr	Every 5,000 Hr	Every 6,000 Hr	Every 10,000 Hr	Every 200,000 Gal (760,000 L) of fuel or 10,000 Hr	Every 12,000 Hr or 6 Yr	As Required
Diesel Exhaust Fluid Injector (Emission Related Component) - Replace											◆					
Cooling System Coolant Extender (ELC) - Add												◆				
DEF Manifold Filters (Emission Related Component) - Replace													◆			
Overhaul Considerations														◆		
Cooling System Coolant (ELC) - Change															◆	
Battery - Recycle																◆
Battery - Replace																◆
Battery or battery Cable - Disconnect																◆
DEF Filter Screen (Emission Related Component) - Clean																◆
Diesel Exhaust Fluid (Emission Related Component) - Clean																◆
Engine - Clean																◆
Engine Air Cleaner Element - Replace																◆
Fuel System - Prime																◆
Fuel Tank Water and Sediment - Drain																◆
Radiator - Clean																◆

---

## Resetting Maintenance Alarms

The controller will display a warning message when the unit is due for maintenance or service. See [Table 4-5](#) for applicable service intervals. Once the unit has been serviced, the appropriate maintenance alarm reminder must be reset. Proceed as follows to reset the maintenance alarms:

1. With the unit shut down, rotate the battery disconnect switch to ON (I). The controller automatically displays to the Home page after initialization.
2. Press ▲, ►, ▼, or ◀ to display the maintenance pages.
3. Simultaneously press ✓ and O. The Configuration menu displays.
4. Press ▼ until the Maintenance group is highlighted.
5. Press ► to display the sections. Press ▼ to highlight the Maintenance section.
6. Press ► to display the parameters and highlight the maintenance alarm that requires reset.
7. Press ✓ to select the editable parameters. The cursor highlights NOT RESET under the selected maintenance alarm. Press ▲ to highlight RESET.
8. Press ✓ to reset the selected maintenance alarm.
9. To perform additional maintenance alarm resets, repeat steps 6–8.

**NOTE:** If the selected maintenance alarm does not require reset, press ▼ to highlight NOT RESET, then press ✓ to return to the parameters section.

10. Press and hold ✓ for five seconds to save changes. Press and hold O for five seconds to discard changes made.

## DEF System Maintenance

### DEF Testing

**NOTE:** Using DEF with the correct concentration is critical to engine and aftertreatment system performance. Extended storage and other conditions can adversely alter the DEF concentration.

If DEF quality is questionable, draw a sample out of the DEF tank or storage tank into a clear container. DEF must be crystal clear. If DEF appears cloudy or has a colored tint, it is likely not within specification. DEF in this condition should not be used. Drain the tank, flush with distilled water, and fill with new DEF. After filling the tank, check DEF concentration.

If the DEF passes the visual and smell tests, check the DEF concentration with a handheld refractometer calibrated to measure DEF.

DEF concentration should be checked when the engine has been stored for extended periods, or if there is

suspicion the engine or packaged DEF has been contaminated with water.

Follow the instructions included with either tool to obtain the measurement.

The correct DEF concentration is 32.5% urea. If the DEF concentration is not within specification, drain the DEF tank, flush with distilled water, and fill with new or good DEF. If packaged DEF is not within specification, dispose of DEF packages and replace with new or good DEF.

**NOTE:** Do not create DEF by mixing agricultural grade urea with water. Agricultural grade urea does not meet the necessary specifications and can damage the aftertreatment system.

### DEF Tank Cleaning

Proceed as follows to clean the DEF tank:

1. Drain DEF tank into a suitable container. See [DEF Disposal](#).
2. Flush DEF tank with distilled water, and fill with new or good DEF.

### DEF Disposal

Large amounts of DEF should be contained. If large spills occur, contact local environmental authorities for assistance with clean up.

If a substantial quantity of DEF is not within specification, contact the DEF supplier for assistance with disposal. Do not dump large quantities of DEF onto the ground or send DEF to wastewater treatment facilities.

### DEF Tank Refilling

---

#### **WARNING**

Personal injury. Avoid prolonged contact with skin. Wash skin thoroughly with soap and water. Remove contaminated clothing and wash before reuse. Seek medical attention if skin becomes irritated. Failure to do so could result in personal injury. (000338a)

---

#### **CAUTION**

Equipment Damage. Immediately clean any surfaces with water that come in contact with diesel exhaust fluid. Failure to do so could result in equipment damage. (000365)

---

**IMPORTANT NOTE:** If DEF is filled into engine fuel tank or other fluid compartment, do not operate engine until system is properly purged of DEF. Contact a GMASD immediately to determine how to clean and purge the system.

**NOTE:** Use only distilled water to rinse components that are used to deliver DEF. Tap water can contaminate DEF. If distilled water is not available, rinse with clean tap water, then thoroughly rinse with ample amounts of DEF.

Reasonable care should be taken when refilling the DEF tank. Verify the DEF tank cap area is free of debris before removing the cap. Wipe clean with a lint free cloth to remove debris from tank cap. Seal DEF containers between use to prevent contamination and evaporation. Avoid splashing DEF, and do not allow DEF to come into contact with skin, eyes, or mouth.

**NOTE:** Keep anything used to store or dispense DEF clean of dirt and dust. Wash and rinse containers or funnels thoroughly with distilled water to remove contaminants.

If an unapproved fluid, such as diesel fluid or coolant is added to the DEF tank, flush DEF tank with distilled water, and fill with new or good DEF, contact a GMASD, to determine how to clean and purge the system.

If water has been added to the DEF tank, a tank cleaning is necessary. After refilling the tank, check the DEF concentration. See [DEF Testing](#). The operator must maintain appropriate DEF levels at all times. Check the DEF level daily and refill the tank as needed. The filling port is identified by a blue colored cap embossed with the DEF symbol.

## DEF Storage Guidelines

### **WARNING**

Risk of poisoning. Do not ingest diesel exhaust fluid. Seek medical attention immediately if consumed. Failure to do so could result in serious injury.

(000334)

### **WARNING**

Personal injury. Do not inhale diesel exhaust fluid fumes. If breathing becomes difficult, move to an area with fresh air and seek medical attention immediately. Failure to do so could result in serious injury.

(000335a)

### **WARNING**

Personal injury. Avoid contact with eyes. Flush eyes thoroughly with water and seek medical attention immediately. Failure to do so could result in serious injury.

(000336)

**NOTE:** See the Materials Safety Data Sheet (MSDS) for additional information.

DEF freezes at temperatures below 11.5 °F (-11.3 °C). Do not use additives to reduce the freezing temperature. Additives currently available are more corrosive than DEF, and will cause component and system degradation and negatively impact reliability. For more information, see the operator manual, or contact a DEF supplier.

DEF quality degrades rapidly at temperatures above 140 °F (60 °C). To maintain emissions compliance, the

urea concentration must remain between 31.8–33.2%.

Ideal conditions for storage of DEF are:

- Store at temperature range 23–86 °F (-5–30 °C)
- Store in sealed dedicated containers to avoid contamination and evaporation

Under these conditions, DEF is expected to remain usable for a minimum of 18 months. Storing DEF at higher temperatures can reduce its useful life by approximately six months for every 9 °F (5 °C) above 86 °F (30 °C). Long-term storage in the DEF tank (over 12 months) is not recommended. If long-term storage is necessary, test DEF before operating engine. See [DEF Testing](#).

## DOC, SCR, and DPF Cleaning Operations



### **WARNING**

Risk of Burn. Stay clear of the exhaust system during operation and exhaust filter cleaning. Exposure to hot exhaust gases and components could result in serious injury. (000304)

The exhaust aftertreatment system goes through an automatic cleaning process known as regeneration. Under normal circumstances, regeneration occurs without interrupting the unit operation.



**NOTE:** Always park the unit in a safe location for elevated exhaust temperatures and check for adequate fuel level before beginning the exhaust aftertreatment cleaning process. The cleaning cycle can take an extended period of time (approximately 45 minutes). Cleaning is complete when the regeneration indicator remains off.

## Diesel Particulate Filter Regeneration

**NOTE:** See [Emissions Information](#) in this section for emissions statement.

Regeneration is to increase the exhaust temperature for a given time. The Aftertreatment Regeneration Device (ARD) creates the heat which makes regeneration possible. The regeneration process is used to remove soot from the DPF, and warm up the Selective Catalyst Reduction (SCR) system. The DPF traps both soot and ash. The ash is removed through a manual cleaning process. See [Diesel Particulate Filter—Clean](#) for procedure on the service of the DPF.

## Regeneration Indicators

	<b>Regeneration Active.</b> When illuminated, the system is active. This indicator shows that elevated emission temperatures are possible. This indicator will switch off when regeneration is complete.
	<b>DPF.</b> When illuminated, regeneration is required. This indicator will illuminate when “Time to Regen” is less than a predetermined amount of time.
	The module received a fault indication from the engine ECU informing that the Diesel Particulate Filter has been inhibited.

## Modes of Regeneration

**Automatic:** The Electronic Control Module (ECM) uses multiple inputs from the engine and the machine to determine the best time to perform automatic regeneration. Automatic regenerations can take place throughout the operating cycle of the engine.

The regeneration active indicator will be illuminated when regeneration is being performed. Interruptions of the regeneration are acceptable.

**NOTE:** Automatic adjustments of engine speed may be noticed during regenerations. If regeneration is taking place and the engine is taken to low idle, the engine speed may remain elevated to maintain the regeneration.

**NOTE:** If the machine returns to work while automatic regeneration is active, the regeneration may be stopped. The ECM will continue to monitor inputs to determine the best time to restart the regeneration.

## Regeneration Triggers

See [Table 4-6](#). Regeneration may be required for the following reasons.

**Soot:** The DPF will collect soot produced by the engine. Automatic regeneration activates to reduce soot level.

**Start-Up Regeneration:** Start-up regeneration is initiated by the ECM after a cold engine start. This regeneration is performed to heat the system to a required temperature for Diesel Exhaust Fluid (DEF) dosing to begin.

**SCR Maintenance:** Regeneration is performed to maintain the SCR system.

**ARD Maintenance:** Regeneration is performed to maintain the CRS system.

## Regeneration System Warning Indicators

See [Figure 4-3](#). The DPF Indicator will illuminate solid when regeneration is required. Regeneration should be

performed as soon as possible.

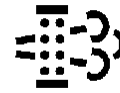
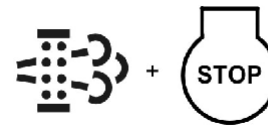

**Figure 4-3. DPF Indicator**

**NOTE:** In some situations, the DPF indicator may stay illuminated after regeneration ends. The illuminated DPF indicator indicates that complete regeneration has not been performed. Complete regeneration is when the soot has been depleted or all the criteria for one of the other regeneration types have been met. If the DPF indicator stays illuminated, perform regeneration without interruption. The DPF indicator will shut off when regeneration is complete.

If the soot load is above a threshold or sulfur is high, then regeneration is required. The DPF indicator will illuminate and flash slowly. Engine power will be slightly derated. If the machine continues to operate without regeneration, derate will eventually reach 100%. Stop the machine. With the engine at low idle, initiate manual regeneration.

See [Figure 4-4](#). Once the amount of soot collected in the DPF has reached a threshold or “Time to Regen” has been at 0 hours for a predetermined time, the DPF indicator will illuminate and flash at a fast rate. A red stop lamp will illuminate solid.



**Figure 4-4. DPF Indicator and STOP Lamp**

10 minutes after the illumination of the DPF indicator and red stop lamp the engine will stop. The engine can be restarted by cycling the engine start switch key. The engine will return to the previous derate state before shutdown.

Once the amount of soot collected reaches a threshold level or 6.4 hours of run time has passed since the red stop lamp was illuminated without successful regeneration, the engine will have a 100% derate.

Once the amount of soot collected reaches a critical threshold level, the regeneration will be locked out. Now, regeneration can only be performed by using electronic service tool (ET). The engine may be restarted, but will only run for 3 minutes before shutting down again.

A fault code will be active for any DPF system-related issue. Follow the troubleshooting guide to rectify the issue.

If the DPF loses function, or is tampered with in any way, the check engine lamp, and an amber action (if equipped) will illuminate. A fault code will also announce. The lamps and fault code will remain active until the problem is rectified.

**NOTE:** The engine and emissions control system shall be operated, used, and maintained in accordance with the instructions provided. Failure to follow the instructions could result in emissions performance that does not meet the requirements applicable to the category of the

engine. No deliberated tampering with, or misuse of the engine emissions control system should take place. Prompt action is critical to rectify any incorrect operation, use, or maintenance of the emissions control system.

**Table 4-6. Regeneration Triggers**

Type	Reason For Trigger	Strategy	Regen Interval	Duration (Minutes)
Primary Triggers (LSR & HSR)	A/T maintenance	Upon cold startup (coolant temp. below 104 °F (40 °C), the A/T will be maintained.  Coolant temp. must reach 104 F° (40 C°) before regeneration will occur.  Shutoff after 17 min.	On cold startup.  Frequency depends on how often application starts up cold.	17
Secondary SMART Triggers (LSR & HSR)	DPF soot level	LSR and HSR enabled at 80%.	10 hours to infinite	30–45  Max: 75
	CRS/Deposit maintenance	Fuel must be cycled through main CRS nozzle at least once every 25 hours.	25 hours to infinite.	10–20
	Sulfur*	30 minutes of 842 °F (450 °C) SCR inlet temperature is required every 100 hours.  Smart timer is incremented or decremented based on logic.	Infinite—other triggers will currently reduce sulfur adequately.	30
	HC evap*	Model of HC collected in A/T.  After prolonged cranking or long-duration idle at low temperature, trigger 932 °F (500 °C) for an ECU predetermined time interval.	Depending on ambient and operating conditions.	Min: 2> 797 °F (425 °C)  Max: 30 (de-icing strategy)

\*Does not impact Time to Regeneration (hours) timer.

## Checking Generator Drive Plate Torque



Accidental Start-up. Disconnect the negative battery cable, then the positive battery cable when working on unit. Failure to do so could result in death or serious injury. (000130)

1. Disconnect battery.
2. Remove generator fan guard.
3. Tighten each drive plate bolt to 44 ft-lb (56.9 Nm).
4. Install generator fan guard.
5. Connect battery.

## Jack Maintenance

The following procedures should be performed annually.

### Side-Wind Models

- The internal gearing and bushings of the jack must be kept lubricated. Apply a small amount of automotive grease to the internal gearing by removing the jack cover, or, if equipped, use a needle-nose applicator or standard grease gun on the lubrication point on the side of the jack near the crank. Rotate the jack handle to evenly distribute grease.
- Lightweight oil must be applied to the handle, at both sides of the tube.
- If equipped, the axle bolt and nut assembly of the caster wheel must also be lubricated with the same lightweight oil.

## Top-Wind Models

- Apply a light weight oil to the screw stem.

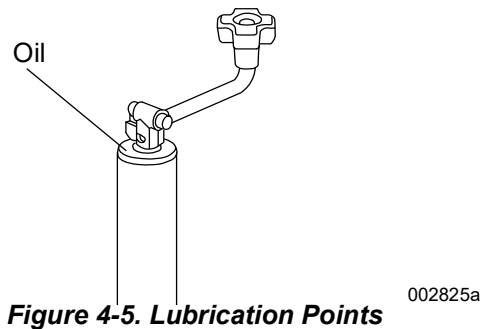
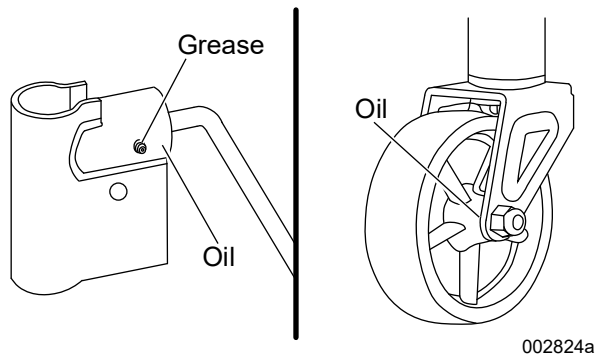
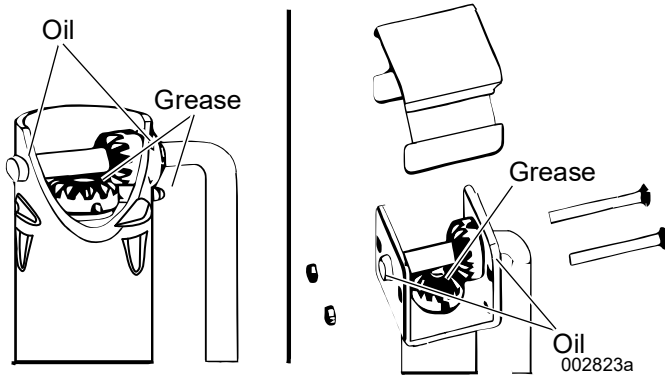

**Figure 4-5. Lubrication Points**

## Trailer Wheel Bearings

The trailer axles are equipped with oil bath bearings. The clear plastic cap serves as a site glass to verify oil level in the axles. The cap should be tightened to 25 ft-lb. Over tightening can damage the sealing o-ring and cause an oil leak. The oil can be refilled through the clear cap by removing the rubber plug in the center of the cap. Please use one of the recommended oils to lubricate the bearings:

- SAE 90
- SAE 80W-90
- SAE 75W-90

In order to remove the hub/rotor assembly a gear puller may be required. The oil seal is a 2-part seal where the inside diameter of the seal presses onto the spindle journal and the outside diameter of the seal presses into the hub bore. A gear puller is the most efficient way to remove the hub from the spindle. A new oil seal must be

installed before reassembly or the old seal will leak upon re-installation and use. When re-installing a new oil seal, be sure to correctly orient the seal. Most are marked AIR SIDE. This side must not be placed towards the oil and bearing or it will fail in service. Install new seal using a block of wood and hammer to drive in the seal bore square until the outer face is flush with the seal bore face. Do not use permatex on rubber-encased oil seals.

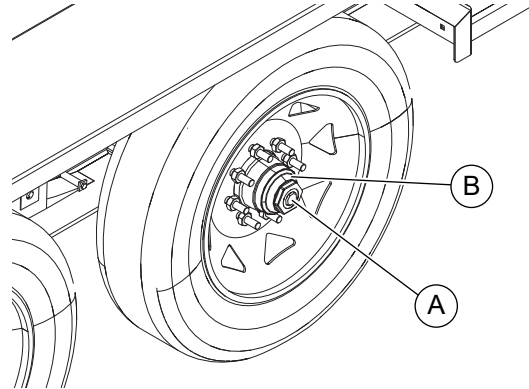

**Figure 4-6. Hub Assembly**

- A Rubber cap
- B Clear plastic cap

014867



---

This page intentionally left blank.

# Section 5: Troubleshooting

## General Troubleshooting

This information is intended to be a check or verification for simple causes that can be located and fixed. It does not cover all types of problems. See the OEM engine manual for additional troubleshooting information.

Procedures that require in-depth knowledge or skills should be performed by a GMASD.

Problem	Possible Causes	Solution
Low fuel level shutdown	Low fuel level	Check fuel level on controller.
	Unit not level	Verify unit is sitting level to ensure an accurate reading.
	Leaking fuel tank	Check tank for leaks.
	Damaged fuel sender or wiring	Check for continuity between sender and engine controller.
Low oil pressure shutdown	Low oil level	Check oil level on dipstick. Add oil if necessary.
	Leaking oil from engine	Visually inspect the engine for leaks. Restart unit and verify loss of pressure. Immediately stop engine if pressure does not reach 5 psi (34.5 kPa) within five seconds.
	Oil pressure sender	See the OEM engine manual to identify corrective action.
Low coolant level shutdown	Low coolant level	Allow engine to cool, then check coolant level in radiator. Add coolant if necessary.
	Leaking coolant hoses	Inspect hoses for leaks. Repair or replace as necessary.
	Leaking engine block or water pump	Visually inspect for leaks. Verify no coolant has mixed with the engine oil (oil will appear milky). See the OEM engine manual for additional information.
High coolant temperature shutdown	Low coolant level	Add coolant if necessary. Allow engine to cool, then check coolant level in radiator. Restart engine and check coolant temperature (on controller). Immediately stop engine if coolant temperature is 210 °F (99 °C) or higher.
	Blockage in radiator	Check radiator shroud and ducting for blockage and remove any foreign matter.
	Leakage in coolant hoses, engine block, or water pump	<ul style="list-style-type: none"> <li>Inspect for visible leaks. Check tension of water pump serpentine drive belt.</li> <li>Remove load on generator and restart engine. Check coolant temperature and immediately stop engine if it starts to overheat. See the OEM engine manual for additional information on engine overheating.</li> </ul>
Overcrank shutdown	Fuel level low	<ul style="list-style-type: none"> <li>Check fuel level in tank.</li> <li>Check fuel pump operation.</li> <li>Check air filter for blockage.</li> <li>See the OEM engine manual for additional information.</li> </ul>

---

This page intentionally left blank.

# Section 6: Wiring Diagrams

## Wiring Diagrams

GROUP G

### LEGEND

AFF - AUX FUEL PUMP	FB - DC FUSE BOX IN ENGINE BAY	TB_ - TERMINAL BLOCK
AFS - AUX FUEL SWITCH	FB_ - FUSE BLOCK	TCR - TELEMETRY CONNECTOR
ALT - DC CHARGE ALTERNATOR	GEN - GENERATOR	VSC_ - VOLTAGE SENSING CONNECTOR
ATB - LSA GENERATOR TERMINAL BLOCK	GFCI - GROUND FAULT CURRENT INTERRUPT	VSS - VOLTAGE SELECTOR SWITCH
AVR - AUTOMATIC VOLTAGE REGULATOR	GND1 - GROUND BAR CONNECTION	WLS - COOLANT LEVEL SENDER
AVRC - AVR CONNECTOR	HDB - HEATER DISTRIBUTION BOX	XMFR1 - BUCK TRANSFORMER
BCH - BATTERY CHARGER	HM - HOUR METER	
BCR - BATT CHARGER SHORE POWER RECEPT	HSP - AC HEATER SHORE POWER RECEPTACLE	
BD - BATTERY DISCONNECT	IL - INTERIOR LED LIGHTING	
BWDL - BATTERY WAIT TO DISCONNECT LAMP	LB - LINK BOARD (OUTPUT VOLTAGE SELECT)	
CB_ - RECEPTACLE CIRCUIT BREAKERS	LIS - LOW IDLE SWITCH	
CBC - (MLCB) CIRCUIT BREAKER CONNECTOR	MLCB - MAIN LINE CIRCUIT BREAKER	
CC_ - CUSTOMER CONNECTION LUGS	MLS - MASTER LIGHT SWITCH	
CT_ - CURRENT TRANSFORMER	OLS - OIL LEVEL SWITCH	
CTC - CURRENT TRANSFORMER CONNECTOR	PAS - POSITIVE AIR SHUTDOWN	
CVH - CRANKCASE VENT HEATER	PASP - PAS POSITION RELAY	
DCS - DEF CONTAINMENT SWITCH	PL - CONTROL PANEL LIGHT	
DS_ - DEEP SEA 8610 CONTROLLER CONNECTOR	PWR - POWER ZONE POWER CONNECTOR	
DSE - DEEP SEA 8610 ETHERNET PORT	PZC - MAIN POWER ZONE CONNECTOR	
DSI_ - DEEP SEA I/O EXPANSION MODULE CONNECTOR	RBS - RUPTURE BASIN LEAK DETECT SWITCH	
DSW1 - CUSTOMER LUG DOOR SAFETY SWITCH	SC - START CONTACTOR	
DSW2 - LINK BOARD DOOR SAFETY SWITCH	SM - STARTER MOTOR	
ES_ - EMERGENCY STOP SWITCH	SMS - STARTER MAGSWITCH	

### ALL CONNECTORS SHOWN FROM WIRE INSERTION VIEW UNLESS OTHERWISE NOTED

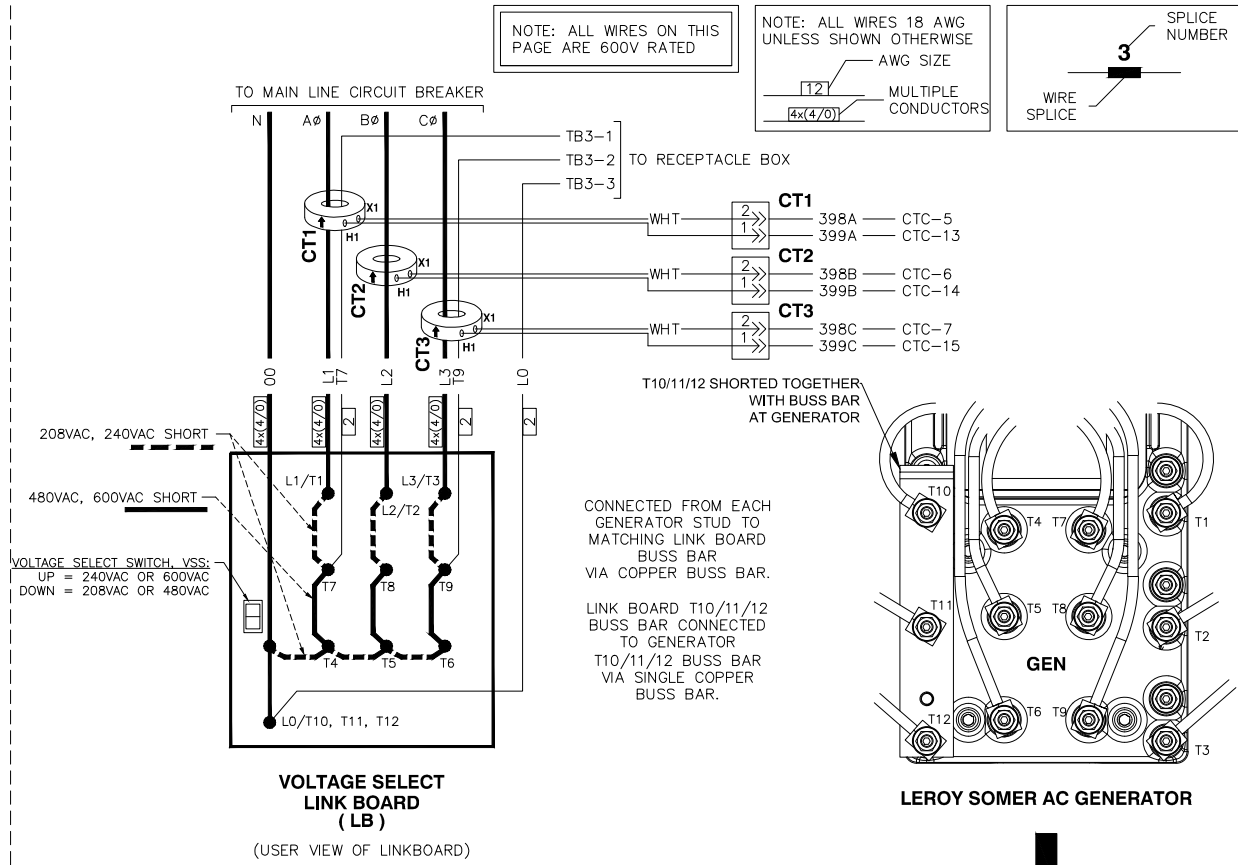

### WIRING FOR GENERATOR & LINK BOARD

FRONT OF UNIT

PAGE 1 OF 16

WIRING - DIAGRAM

D18.1L G22 DS8610 MDE

DRAWING #: A0002077361

REVISION: CN-0058927-C

DATE: 9/16/22

PAGE 1 OF 16

DIAGRAM

GROUP G

COMPONENTS LOCATED IN CIRCUIT BREAKER BOX

NOTE: ALL WIRES ON THIS PAGE ARE 600V RATED

WIRING FOR MANUAL & MOTORIZED MLCB

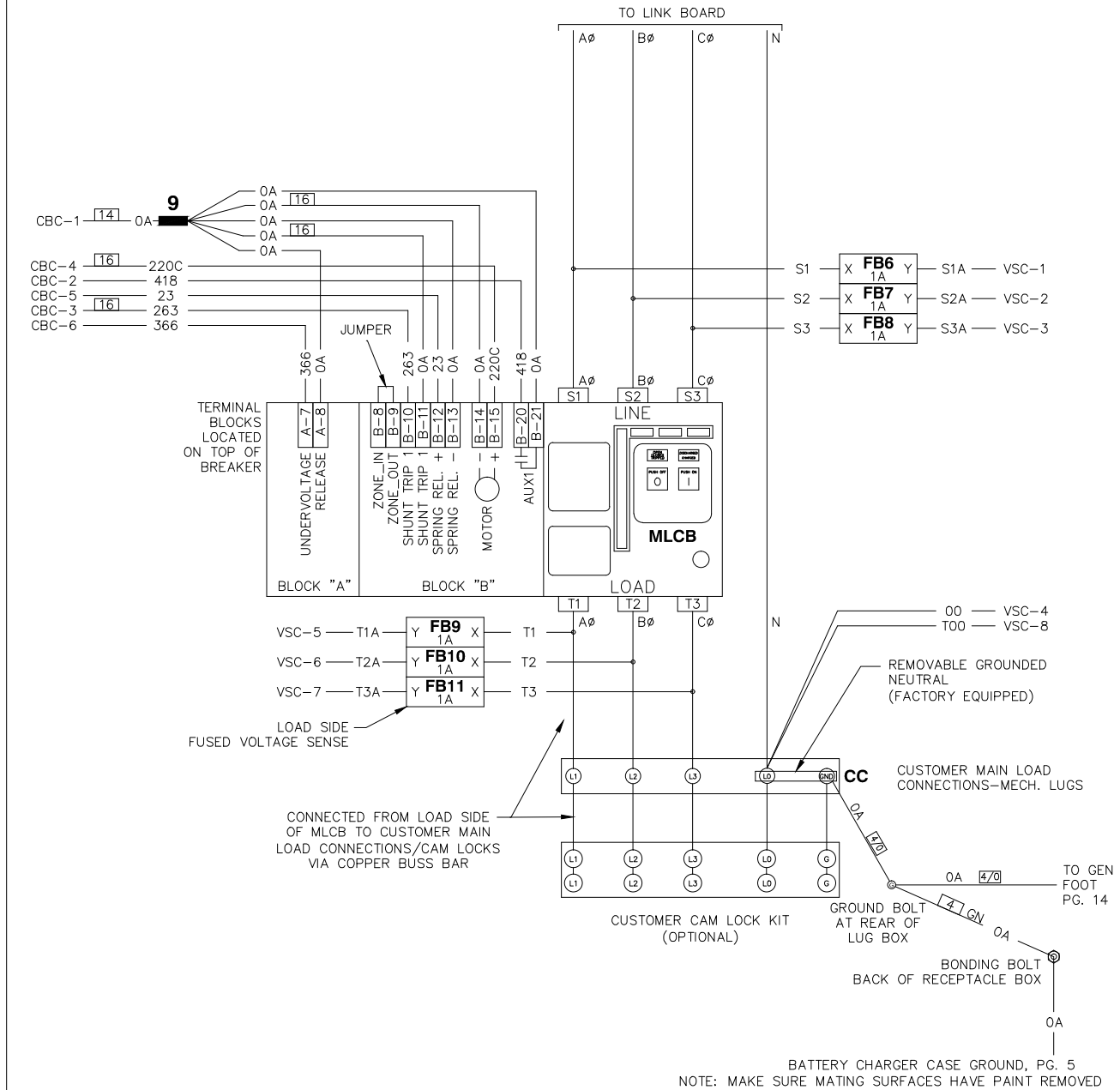

DIAGRAM

GROUP G

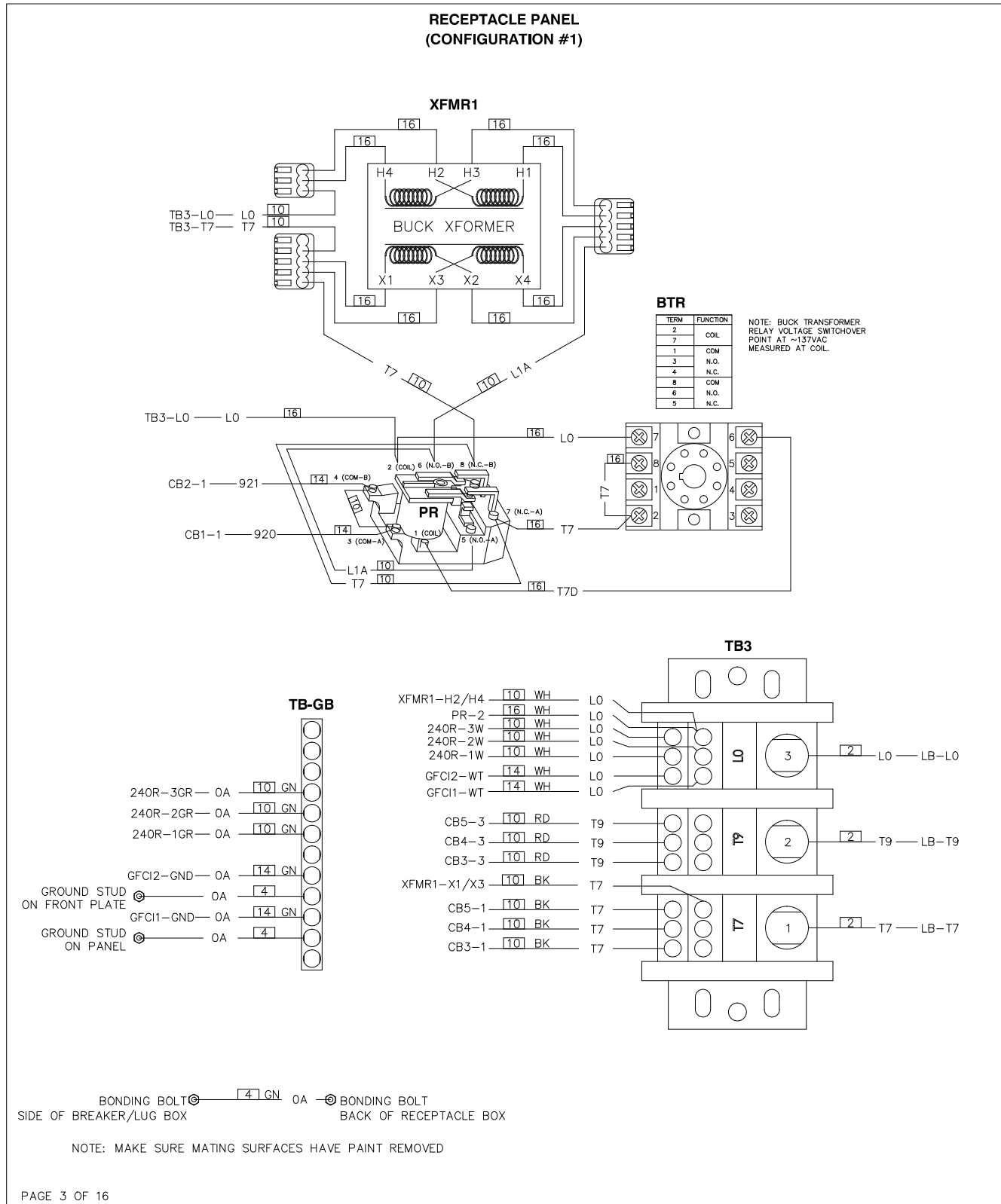

DIAGRAM

GROUP G

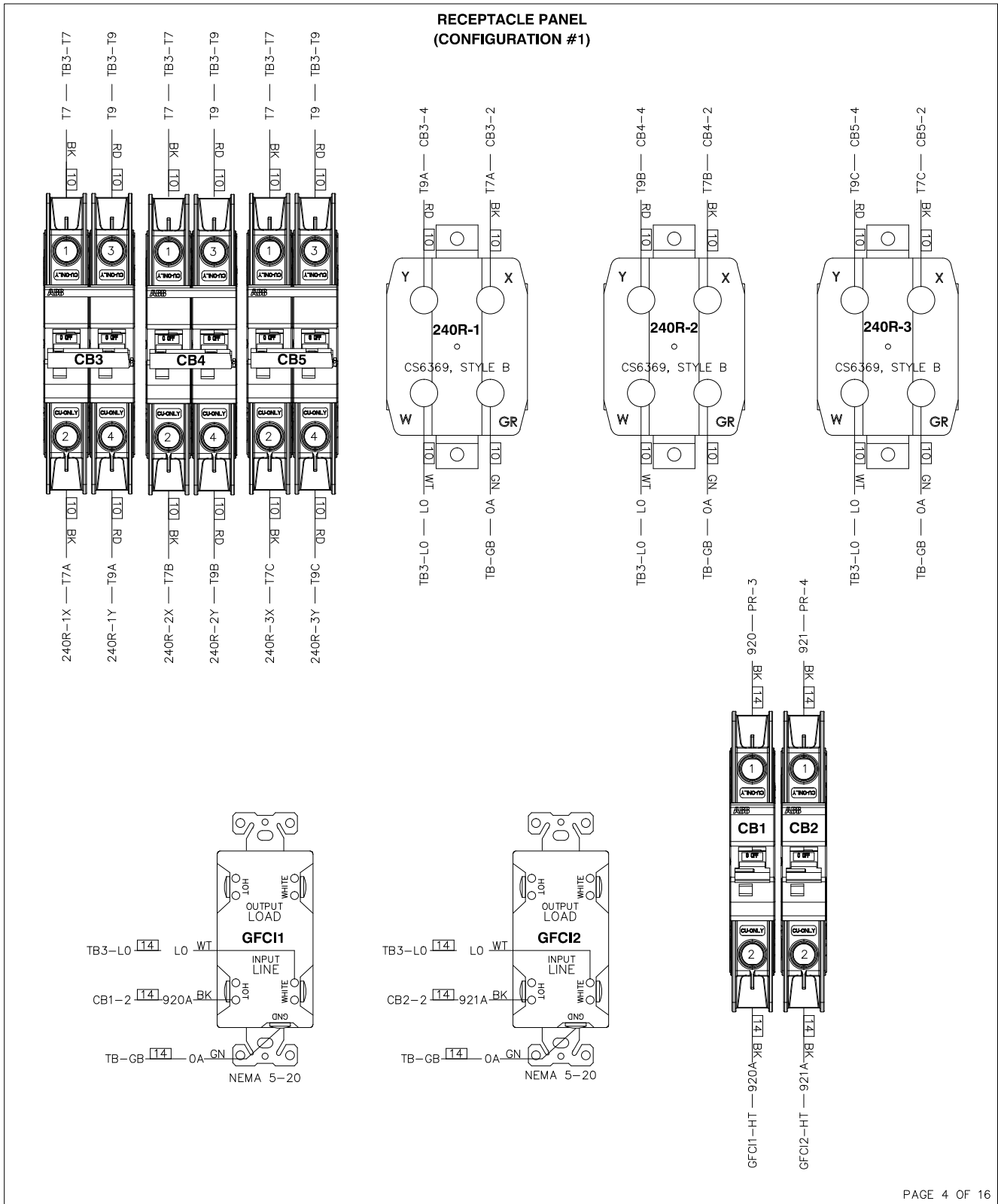



DIAGRAM

GROUP G

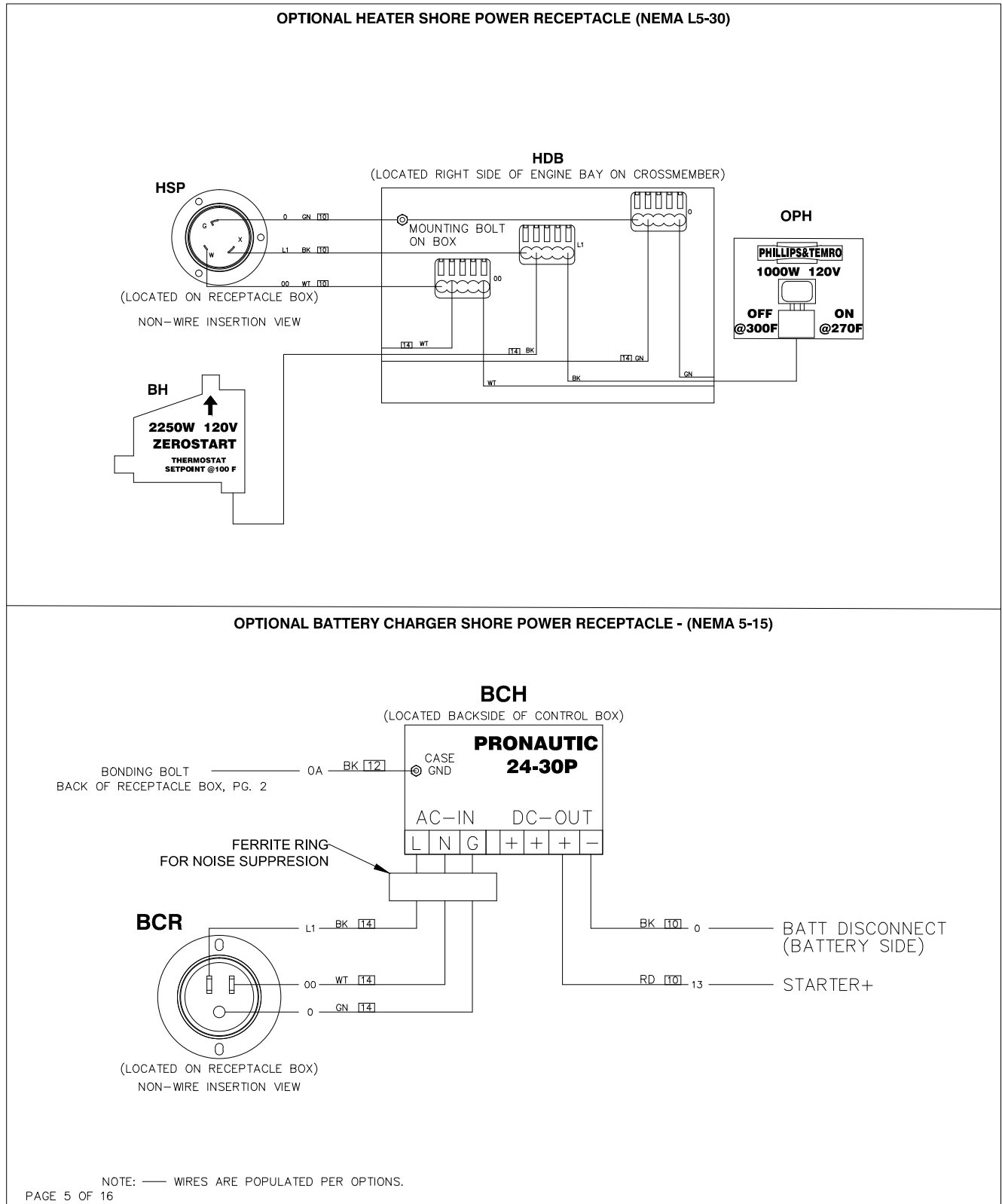

REVISION: CN-0058927-C  
DATE: 9/16/22

PAGE 5 OF 16

WIRING - DIAGRAM  
D18.1L G22 DS8610 MDE  
DRAWING #: A0002077361

DIAGRAM

GROUP G

COMPONENTS LOCATED IN CONTROL PANEL

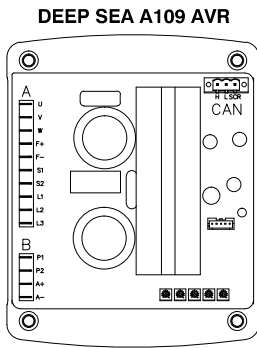

CONNECTOR A			CONNECTOR B			CAN		
PIN	WIRE	FROM	PIN	WIRE	FROM	PIN	WIRE	FROM
U	2	AVRC-1	P1	-	-	H	743A	DS3-26
V	5	AVRC-2	P2	-	-	L	744A	DS3-27
W	6	AVRC-3	A+	-	-	SCR	-	-
F+	4	AVRC-5	A-	-	-			
F-	1	AVRC-4	CUT	-	-			
S1	-	-						
S2	-	-						
L1	T7	AVRC-10						
L2	T9	AVRC-9						
L3	-	-						

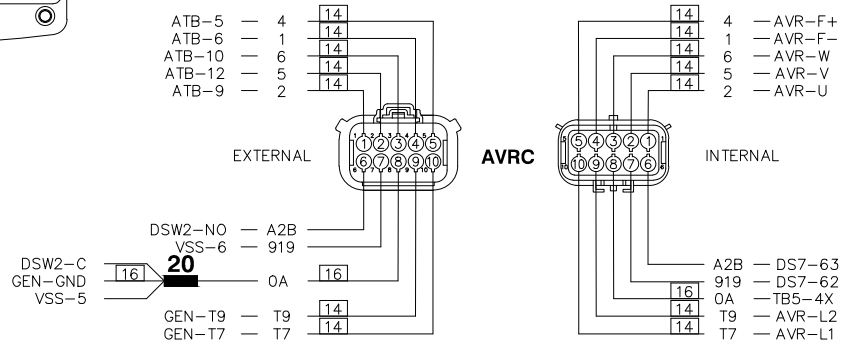

COMPONENTS LOCATED IN ALTERNATOR

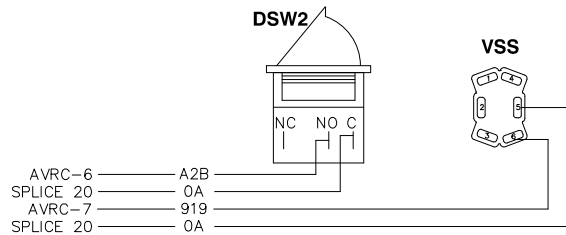
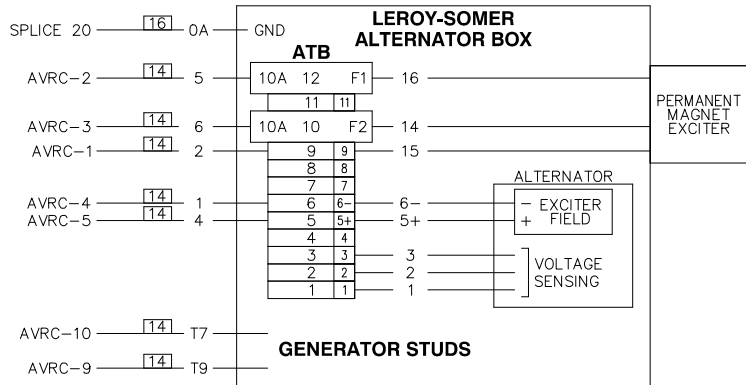

DIAGRAM

GROUP G

COMPONENTS LOCATED IN CONTROL PANEL

NOTE: ALL WIRES ON THIS PAGE ARE 600V RATED

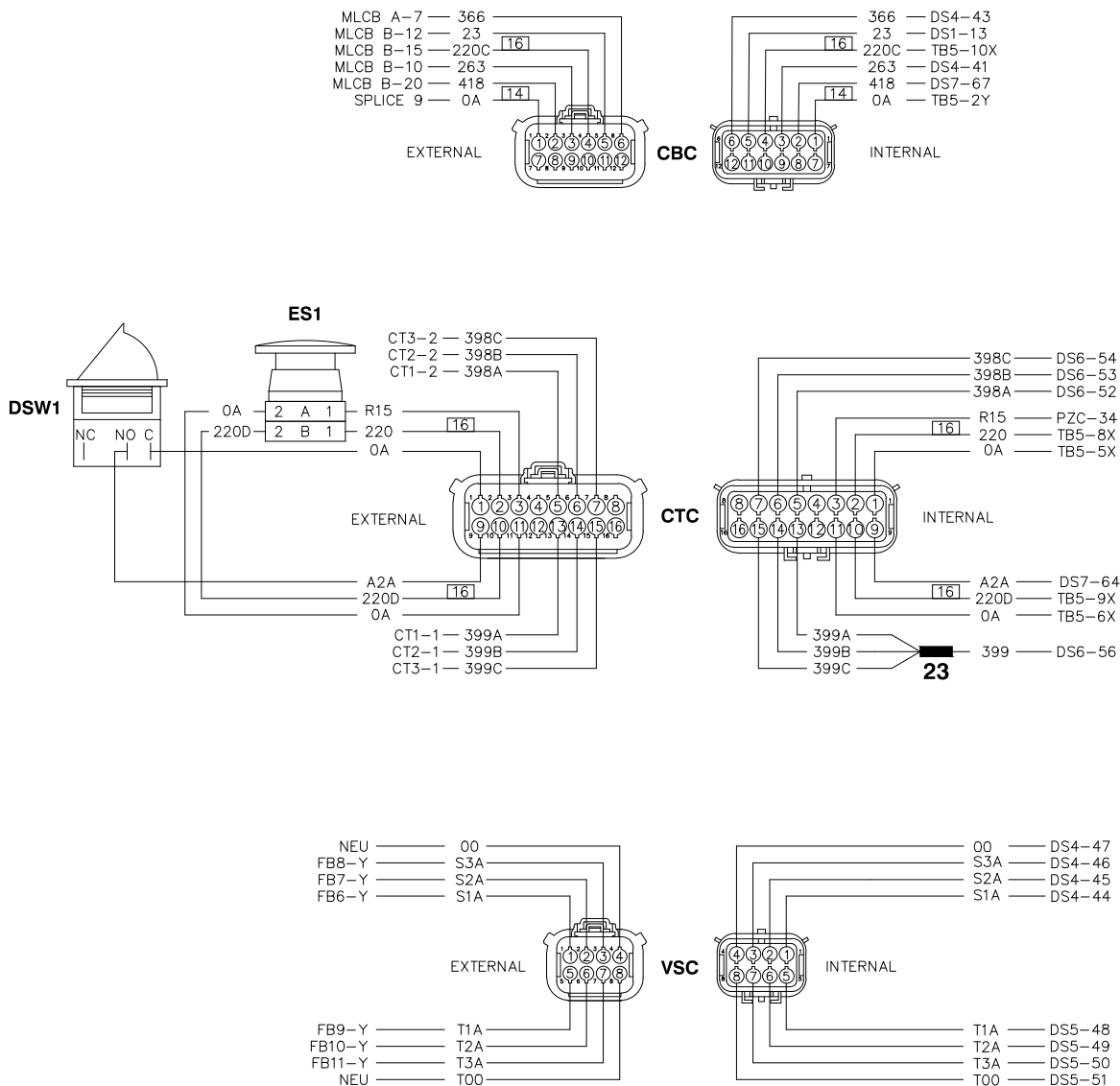

DIAGRAM

GROUP G

COMPONENTS LOCATED IN CONTROL PANEL

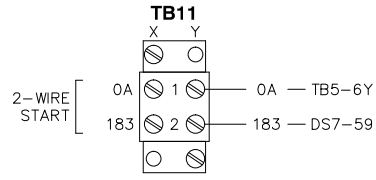
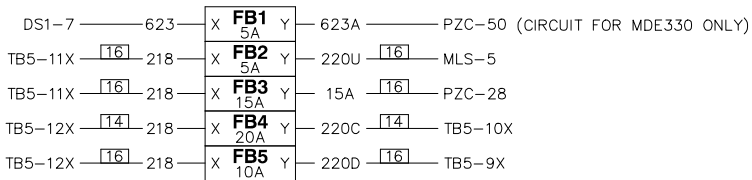
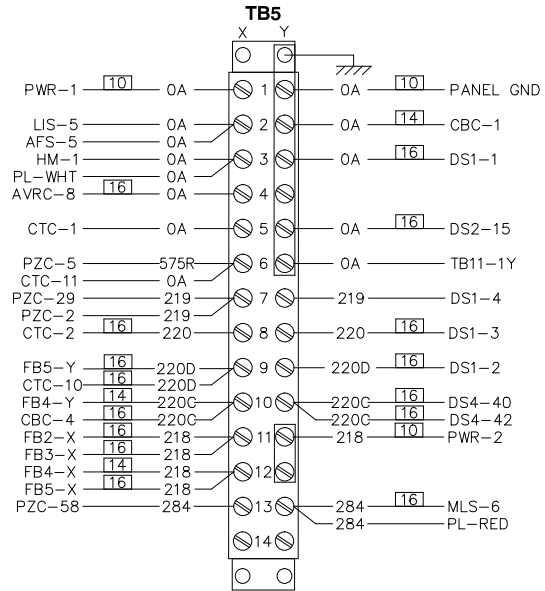

COMPONENTS LOCATED ON CONTROL PANEL INNER DOOR

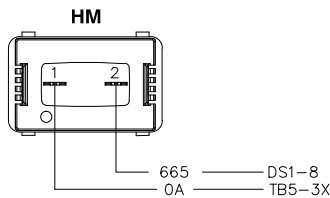
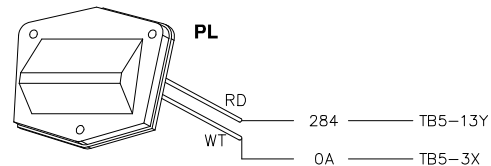
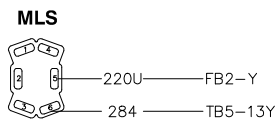
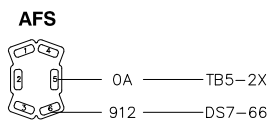
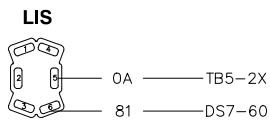

DIAGRAM

GROUP G

COMPONENTS LOCATED ON CONTROL PANEL INNER DOOR

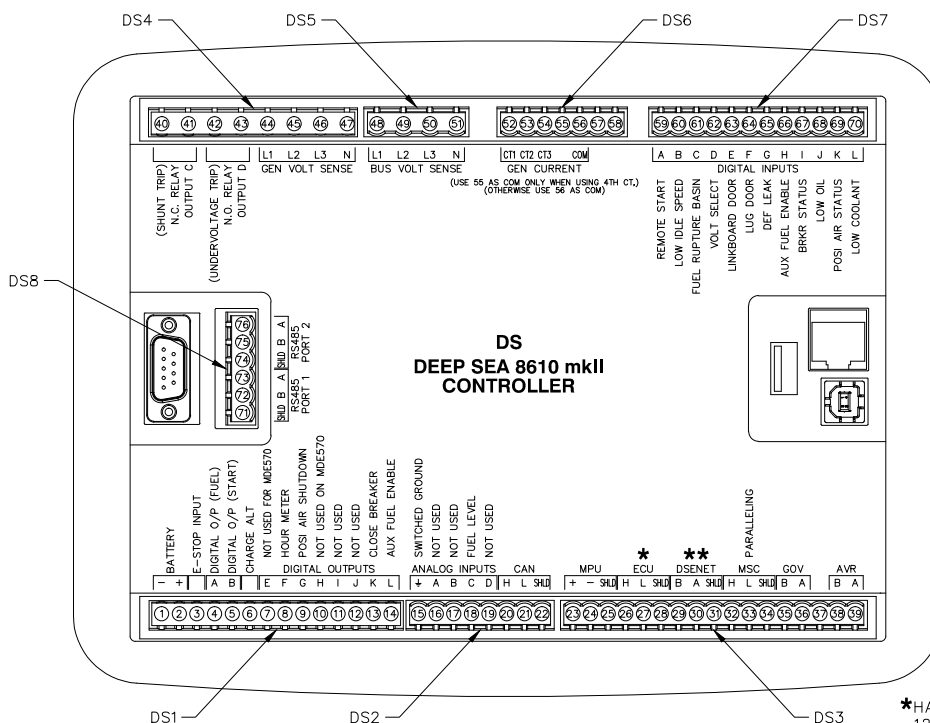

\*HAS SOFTWARE ENABLED 120Ω RESISTOR.  
 \*\*HAS INTERNALLY TERMINATED 120Ω RESISTOR.

DS1

PIN	WIRE	FROM
1	0A	TB5-3Y
2	220D	TB5-9Y
3	220	TB5-8Y
4	219	TB5-7Y
5	56	PZC-1
6	-	-
7	623	FB-1X
8	665	HM-2
9	285	PZC-56
10	882	PZC-60
11	-	-
12	-	-
13	23	CBC-5
14	910	PZC-59

DS2

PIN	WIRE	FROM
15	0A	TB5-5Y
16	-	-
17	-	-
18	575S	PZC-4
19	-	-
20	-	-
21	-	-
22	-	-

DS3

PIN	WIRE	FROM
23	-	-
24	-	-
25	-	-
26	743A	PZC-43
26	743A	AVR-CANH
27	744A	PZC-44
27	744A	AVR-CANL
28	SHLD	PZC-45
28	SHLD	CUT
29	-	-
30	-	-
31	-	-
32	743B	Y4-B
33	744B	Y4-C
34	SHLD	Y4-A
35	-	-
36	-	-
37	-	-
38	-	-
39	-	-

DS4

PIN	WIRE	FROM
40	220C	TB5-10Y
41	26.3	CBC-3
42	220C	TB5-10Y
43	366	CBC-6
44	S1A	VSC-1
45	S2A	VSC-2
46	S3A	VSC-3
47	00	VSC-4

DS5

PIN	WIRE	FROM
48	T1A	VSC-5
49	T2A	VSC-6
50	T3A	VSC-7
51	T00	VSC-8

DS6

PIN	WIRE	FROM
52	398A	CTC-5
53	398B	CTC-6
54	398C	CTC-7
55	-	-
56	399	SPLICE 23
57	-	-
58	-	-

DS7

PIN	WIRE	FROM
59	183	TB11-2Y
60	81	LIS-6
61	567	PZC-6
62	919	AVRC-7
63	A2B	AVRC-6
64	A2A	CTC-9
65	D15	PZC-52
66	912	AFS-6
67	418	CBC-2
68	86	PZC-10
69	0B	PZC-57
70	573	PZC-7

DS8

PIN	WIRE	FROM
71	SHLD	PZC-48
72	391	PZC-47
73	390	PZC-46
74	-	-
75	-	-
76	-	-

DIAGRAM

GROUP G

COMPONENTS LOCATED AT BACK OF CONTROL PANEL BOX

	PIN	WIRE	AWG	FROM	TO
CRANK	1	56	18	DS1-5	SC
RUN SIGNAL (ACTIVE HI)	2	219	18	TB5-7X	FB-D5
	3	-	-	-	-
FUEL LEVEL, 2WIRE	4	575S	18	DS2-18	FLS-1
FUEL LEVEL, 2WIRE	5	575R	18	TB5-6X	FLS-2
FUEL CONTAINMENT	6	567	18	DS7-61	RBS-1
LOW CLNT LVL	7	573	18	DS7-70	WLS-C
	8	-	-	-	-
	9	-	-	-	-
OIL MAKEUP LEVEL ALARM	10	86	18	DS7-68	OLS-1
	11	-	-	-	-
	12	-	-	-	-

PIN	WIRE	AWG	FROM	TO
13	-	-	-	-
14	-	-	-	-
15	-	-	-	-
16	-	-	-	-
17	-	-	-	-
18	-	-	-	-
19	-	-	-	-
20	-	-	-	-
21	-	-	-	-
22	-	-	-	-
23	-	-	-	-
24	-	-	-	-

PIN	WIRE	AWG	FROM	TO
25	-	25	-	-
26	-	26	-	-
27	-	27	-	-

PIN	WIRE	AWG	FROM	TO
28	15A	16	FB3-Y	SPLICE 5
29	219	18	TB5-7X	TCR-RUN
30	-	-	-	-

DC HEATER  
TELEMETRY RUN

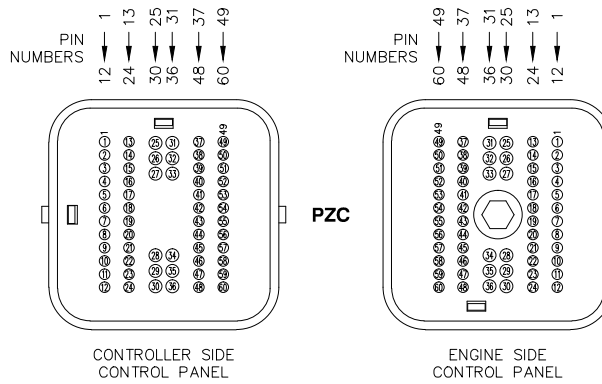

PIN	WIRE	AWG	FROM	TO
31	-	-	-	-
32	-	-	-	-
33	-	-	-	-

AUX SHUTDOWN

PIN	WIRE	AWG	FROM	TO
34	R15	18	CTC-3	EP-23
35	-	-	-	-
36	-	-	-	-

PIN	WIRE	AWG	FROM	TO
37	-	-	-	-
38	-	-	-	-
39	-	-	-	-
40	-	-	-	-
41	-	-	-	-
42	-	-	-	-
43	743A	20	DS3-26	Y16-A
44	744A	20	DS3-27	Y16-B
45	SHLD	20	DS3-28	Y16-C
46	390	20	DS8-73	Y19-A
47	391	20	DS8-72	Y19-B
48	SHLD	20	DS8-71	Y19-C

PIN	WIRE	AWG	FROM	TO
49	-	-	-	-
50	623A	18	FB-1Y	-
51	-	-	-	-
52	D15	18	DS7-65	DCS-1
53	-	-	-	-
54	-	-	-	-
55	-	-	-	-
56	285	18	DS1-9	PAS-1
57	0B	18	DS7-69	FB-D8
58	284	18	TB5-13X	IL-1
59	910	18	DS1-14	FB-D3
60	882	18	DS1-10	-

DEF CONTAINMENT  
POSITIVE AIR SHUTDOWN TRIG  
POSITIVE AIR SHUTDOWN POS  
LIGHTING  
AUX FUEL

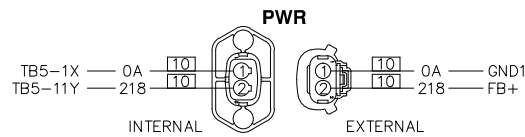





DIAGRAM

GROUP G

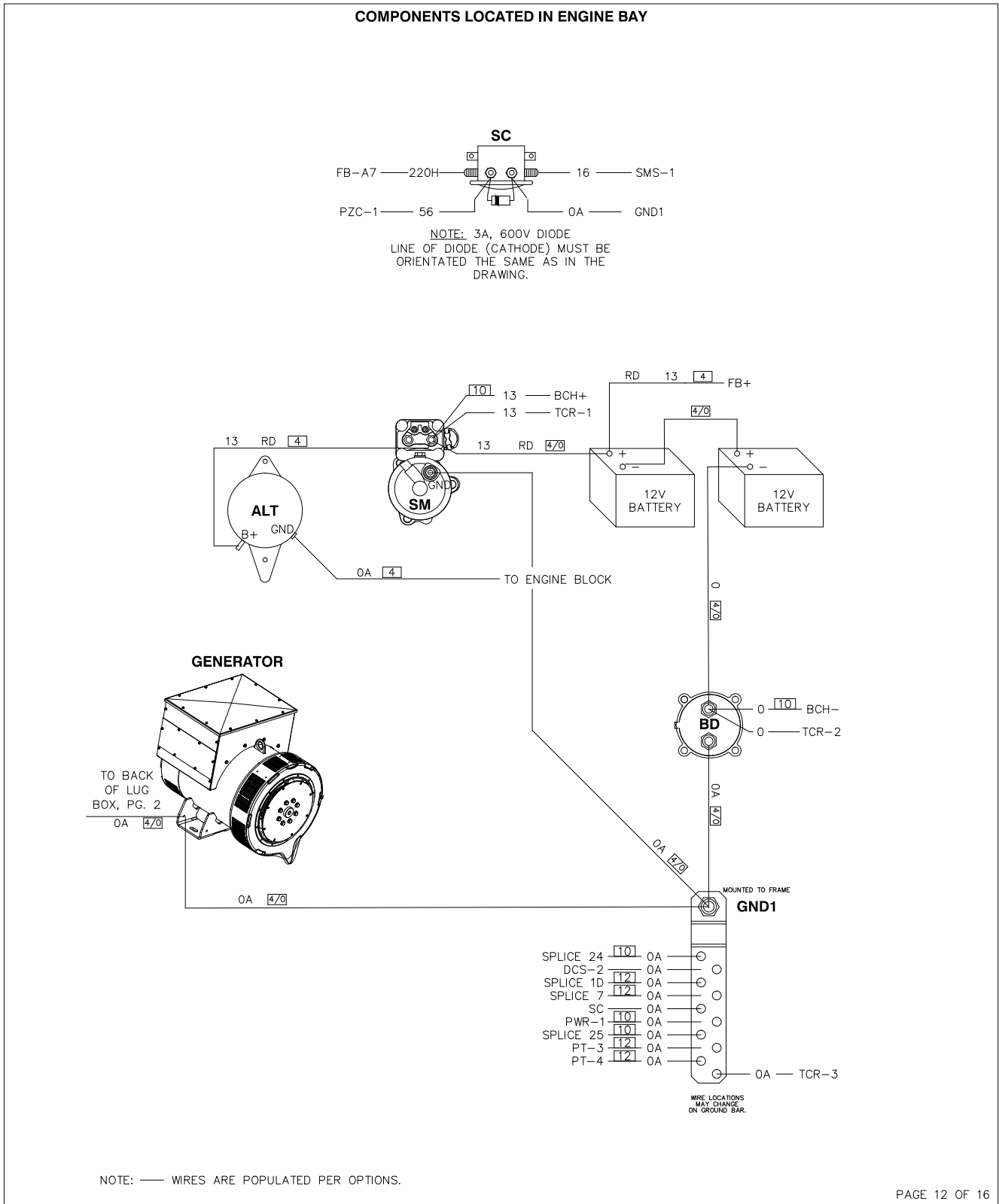

REVISION: CN-0058927-C  
 DATE: 9/16/22

PAGE 12 OF 16

WIRING - DIAGRAM  
 D18.1L G22 DS8610 MDE  
 DRAWING #: A0002077361

DIAGRAM

GROUP G

COMPONENTS LOCATED IN ENGINE BAY

PIN LIST				PIN LIST				PIN LIST				PIN LIST			
PIN	WIRE	AWG	TO	PIN	WIRE	AWG	TO	PIN	WIRE	AWG	TO	PIN	WIRE	AWG	TO
FB				FB				FB				FB			
A1	220J	12	SPLICE 2	B1	220B	14	FB-A2	C1	PLUG	-	-	D1	286	18	EP-37
A2	220B	14	FB-B1	B2	295	18	EP-38	C2	PLUG	-	-	D2	220G	14	EP-39
A3	220P	12	SPLICE 8	B3	220M	14	FB-A9	C3	PLUG	-	-	D3	910	18	PZC-59
A4	220Q	12	SPLICE 4	B4	0A	18	SPLICE 24	C4	PLUG	-	-	D4	220N	16	AFP-1
A5	220R	12	PT-1	B5	0A	18	SPLICE 24	C5	PLUG	-	-	D5	219	18	PZC-2
A6	220T	12	PT-2	B6	0A	18	SPLICE 24	C6	PLUG	-	-	D6	256	18	EP-40
A7	220H	18	SC	B7	0A	18	SPLICE 7	C7	PLUG	-	-	D7	285P	16	PAS-2
A8	220L	16	PAS-3	B8	0A	18	SPLICE 7	C8	PLUG	-	-	D8	0B	18	PZC-57
A9	220M	14	FB-B3	B9	PLUG	-	-	C9	PLUG	-	-	D9	PLUG	-	-
A10	PLUG	-	-	B10	PLUG	-	-	C10	PLUG	-	-	D10	PLUG	-	-

AFPR - AUX. FUEL PUMP RELAY (COMES WITH AFPR OPTION)  
 FPR - PERKINS FUEL PUMP RELAY  
 PASP - PAS POSITION RELAY (COMES WITH PAS OPTION)  
 RUN - RUN RELAY

EXAMPLE FB RELAY WIRING

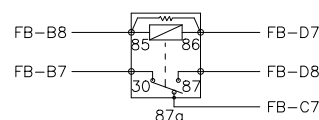

NOTE: TORQUE SPEC FOR FB+  
 40 +/- 5 IN-LB

- A1 - ECU (20A)
- A2 - FUEL PUMP (20A)
- A3 - ECU (20A)
- A4 - ECU (20A)
- A5 - PETU (20A)
- A6 - PETU (20A)
- A7 - STARTER (5A)
- A8 - PAS (15A, COMES WITH PAS OPTION)
- A9 - AFP (15A, COMES WITH AFP OPTION)
- A10 - NOT USED

FUSE BOX (FB) FUSES

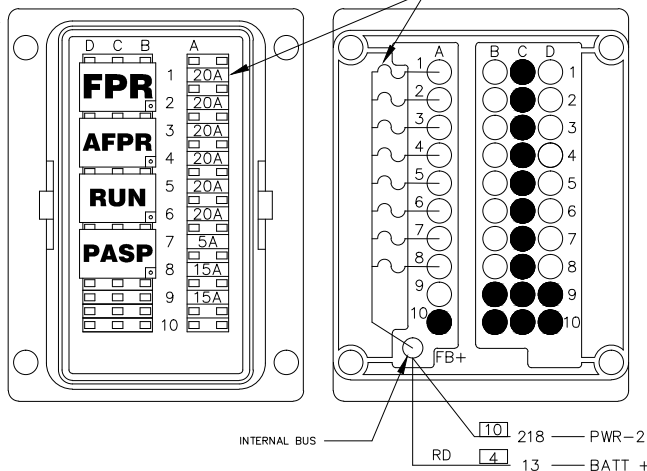

DIAGRAM

GROUP G

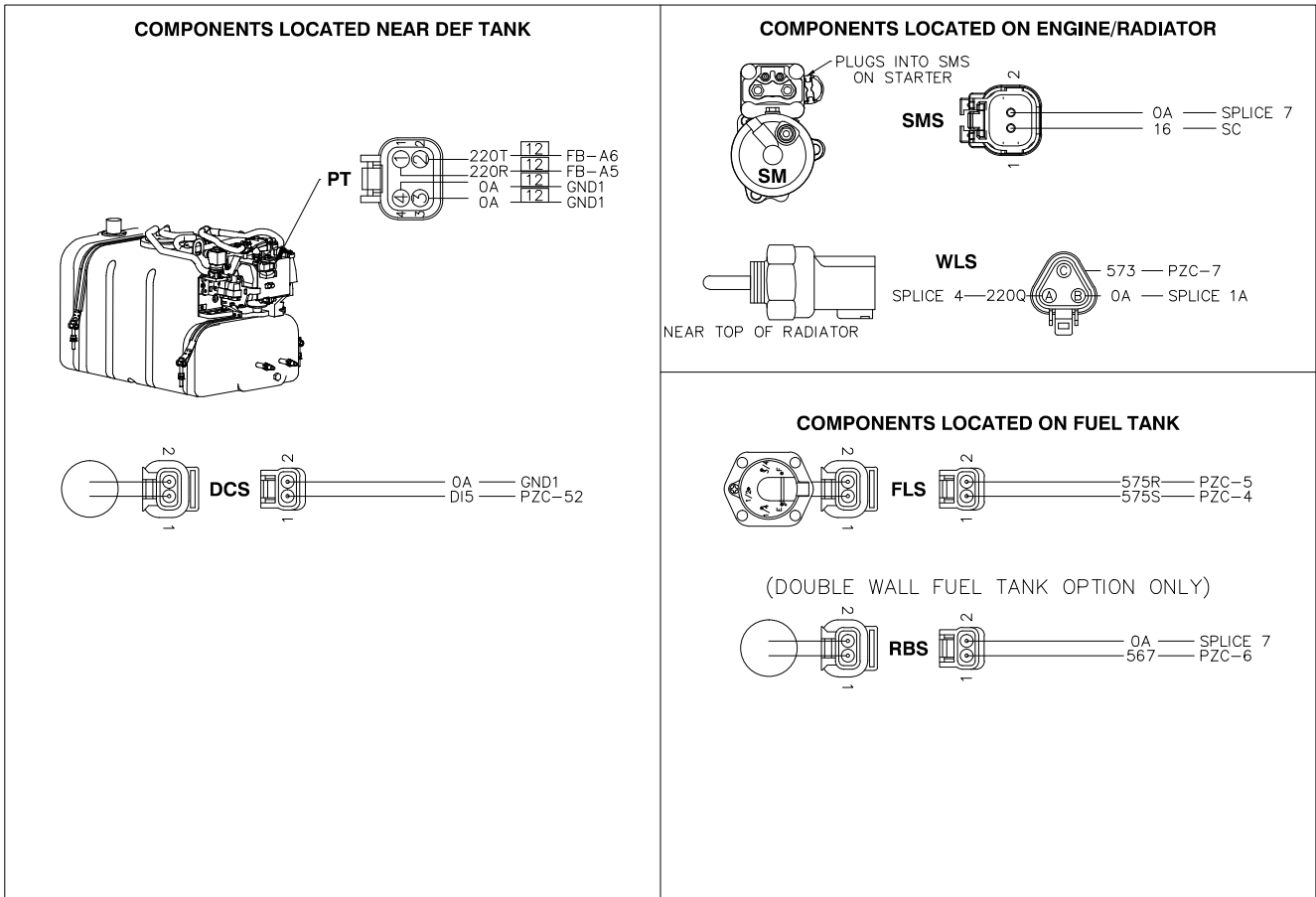

**OPTIONAL TELEMTRY** (MODULE MOUNTED OUTSIDE UNIT ABOVE CONTROL BOX)

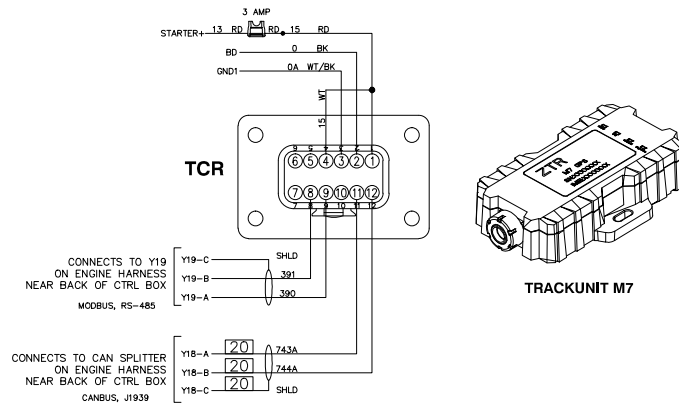

NOTE: WIRES ARE POPULATED PER OPTIONS.

DIAGRAM

GROUP G

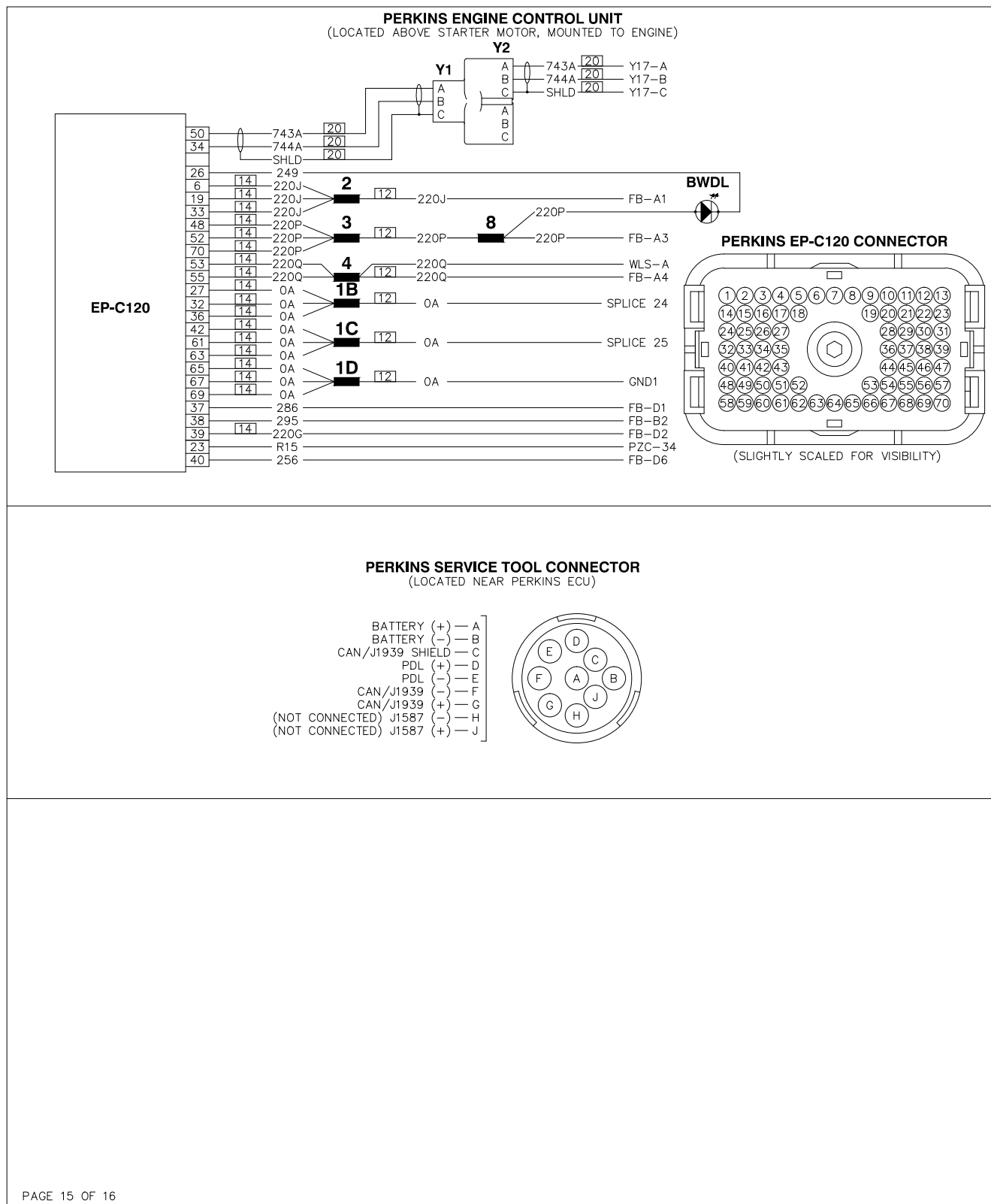

DIAGRAM

GROUP G

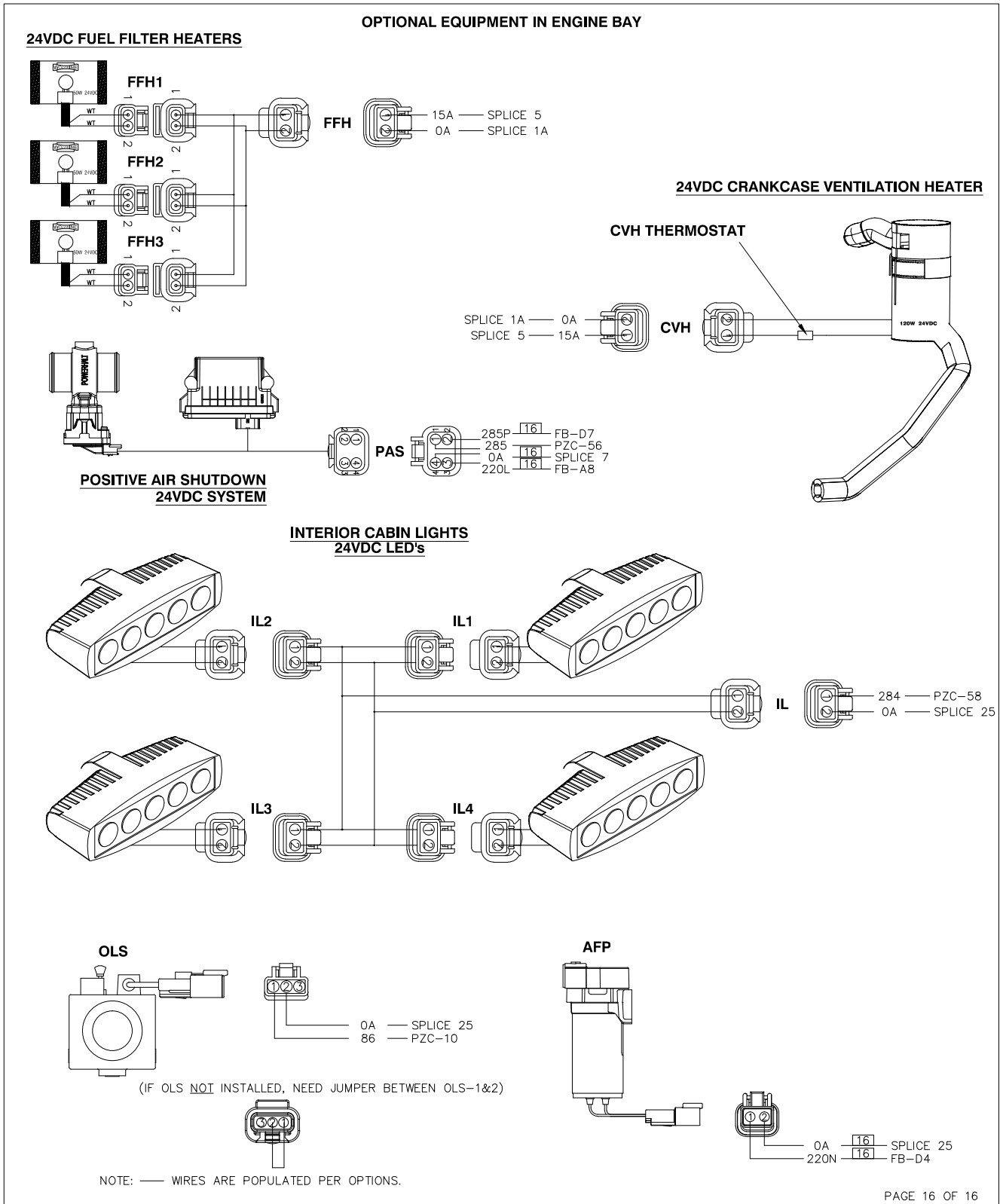



**This page intentionally left blank.**





Part No. A0001515518 Rev. D 02/08/2024

©2024 Generac Power Systems, Inc.  
All rights reserved.  
Specifications are subject to change without notice.  
No reproduction allowed in any form without prior written  
consent from Generac Power Systems, Inc.

**GENERAC** | **MOBILE**

Generac Power Systems, Inc.  
S45 W29290 Hwy. 59, Waukesha WI 53189  
[GeneracMobileProducts.com](http://GeneracMobileProducts.com) | 844-ASK-GNRC | 844-275-